



INSTYTUT TECHNIKI BUDOWLANEJ



Member of



www.eota.eu

European Technical Assessment

**ETA-19/0844
of 22/12/2025**



General Part

Technical Assessment Body issuing the European Technical Assessment

Instytut Techniki Budowlanej

Trade name of the construction product

INTU FR COLLAR
INTU FR COLLAR L
INTU FR SLEEVE

Product family to which the construction product belongs

Fire Stopping and Fire Sealing Products.
Penetration Seals

Manufacturer

ALFASEAL GROUP Sp. z o.o.
ul. Kineskopowa 1
PL 05-500 Piaseczno, Poland

Manufacturing plant

Plant MPA1

This European Technical Assessment contains

48 pages including 6 Annexes which form an integral part of this Assessment

This European Technical Assessment is issued in accordance with regulation (EU) No 305/2011, on the basis of

European Assessment Document (EAD)
350454-00-1104 "Fire Stopping and Fire Sealing Products. Penetration Seals"

This version replaces

ETA-19/0844 issued on 05/08/2020



This European Technical Assessment is issued by the Technical Assessment Body in its official language. Translations of this European Technical Assessment in other languages shall fully correspond to the original issued document and shall be identified as such.

Communication of this European Technical Assessment, including transmission by electronic means, shall be in full. However, partial reproduction may only be made with the written consent of the issuing Technical Assessment Body. Any partial reproduction has to be identified as such.

Specific Part

1 Technical description of the product

INTU FR COLLAR, INTU FR COLLAR L and INTU FR SLEEVE are collar pipe closure devices used to form single penetration seals where metal and combustible pipes, single or in bundles, penetrate walls and floors.

INTU FR COLLAR includes one or more layers of an intumescent, graphite based liner with a nominal thickness of 2,0 mm and width of 30, 40, 50, 60 or 75 mm, inserted into a steel housing made of powder coated steel sheet or stainless steel sheet with a thickness of 0,5 or 1,0 mm.

INTU FR COLLAR L and INTU FR SLEEVE include one or more layers of an intumescent, graphite based liner with a nominal thickness of 2,0 mm and width of 60 mm, inserted into a steel housing made of powder coated steel sheet or stainless steel sheet with a thickness of 0,5 mm. INTU FR SLEEVE has an additional outside layer of intumescent liner on the steel housing.

The housing of INTU FR COLLAR and INTU FR COLLAR L is equipped with a buckle (used to fasten the collar and stabilize it on the service) and with fixing brackets, through which the collar is fixed to the separating element. The number of brackets depends on the size of the collar.

The collar is supplied in assembled form, without fasteners. If necessary, the intumescent liner may be cut to a required length, equal or greater than external circumference of the pipe. The collar is wrapped around the service, closed and then fixed to the separating element with the specified type and number of fasteners (in case of INTU FR COLLAR and INTU FR COLLAR L) or pushed into the aperture in the separating element (in case of INTU FR SLEEVE).

Variants of INTU FR COLLAR, INTU FR COLLAR L and INTU FR SLEEVE, type of fasteners and required number of fixing brackets are presented in Annex A and Annex B.

Auxiliary products used with INTU FR COLLAR, INTU FR COLLAR L and INTU FR SLEEVE are:

- synthetic, flexible elastomeric foam (FEF) in accordance with EN 14304 with reaction to fire class B_L-s3,d0, according to EN 13501-1, and with a nominal density of 40 – 80 kg/m³ (pipe insulation),
- INTU FR MASTIC (gap filler) – covered by ETA-19/0038.

2 Specification of the intended use in accordance with the applicable European Assessment Document (EAD)

2.1 Intended use

The intended use of INTU FR COLLAR, INTU FR COLLAR L and INTU FR SLEEVE is to reinstate the fire resistance performance of flexible wall, rigid wall or rigid floor constructions, where they are penetrated by metal pipes or combustible pipes.

The specific elements of construction that INTU FR COLLAR, INTU FR COLLAR L and INTU FR SLEEVE may be used to provide a penetration seal in, are as follows:

Rigid walls: The wall must have a minimum thickness in accordance with Annex C, Annex D or Annex E, and comprise concrete, reinforced concrete, aerated concrete, ceramic brick, cavity brick or checker brick, with a minimum density of 600 kg/m³.

Flexible walls: The wall must have a minimum thickness in accordance with Annex C, Annex D or Annex E, and comprise timber or steel studs lined on both faces with minimum two layers (with overall board layer thickness on one

side equal to or greater than 25 mm) of type F or type DF gypsum plasterboards according to EN 520. In timber stud walls, no part of the penetration shall be closer than 100 mm to a stud, the cavity must be closed between the penetration seal and the stud and minimum 100 mm of insulation of reaction to fire class A1 or A2, according to EN 13501-1, is provided within the cavity between the penetration seal and the stud.

Rigid floors: The floor must have a minimum thickness in accordance with Annex C, Annex D or Annex E, and comprise concrete or reinforced concrete, with a minimum density of 1700 kg/m³.

The supporting construction shall be classified in accordance with EN 13501-2 for the required fire resistance period (equal to or greater than specified in Annex C, Annex D or Annex E).

INTU FR COLLAR, INTU FR COLLAR L and INTU FR SLEEVE may be used to provide a penetration seal with specific combustible and metal pipes (according to Annex A, Annex C, Annex D or Annex E).

Details of penetration seals are provided in Annex C, Annex D or Annex E and Annex F. Additional provisions are provided in Annex A and Annex B.

The provisions made in this European Technical Assessment are based on an assumed working life of the product of 25 years. The indications given on the working life cannot be interpreted as a guarantee given by the producer or the Technical Assessment Body, but are to be regarded only as a means for choosing the right products in relation to the expected economically reasonable working life of the works.

2.2 Use category

Type Z₂: intended for use in internal conditions with humidity lower than 85% RH, excluding temperatures below 0°C, without exposure to rain or UV.

3 Performance of the product and references to the methods used for its assessment

3.1 Performance of the product

3.1.1 Safety in case of fire (BWR 2)

Essential characteristic	Performance
Reaction to fire	Class E
Resistance to fire	Annex C, Annex D and Annex E

3.1.2 Hygiene, health and the environment (BWR 3)

No performance assessed.

3.1.3 Safety and accessibility in use (BWR 4)

Essential characteristic	Performance
Mechanical resistance and stability	No performance assessed
Resistance to impact / movement	No performance assessed

Essential characteristic	Performance
Adhesion	No performance assessed
Durability	Use category: Type Z ₂

3.1.4 Protection against noise (BWR 5)

No performance assessed.

3.1.5 Energy economy and heat retention (BWR 6)

No performance assessed.

3.2 Methods used for the assessment

The assessment has been made in accordance with EAD 350454-00-1104.

4 Assessment and verification of constancy of performance (AVCP) system applied, with reference to its legal base

According to the Decision 1999/454/EC of the European Commission, as amended by Decision 2001/596/EC of the European Commission, the system 1 of assessment and verification of constancy of performance applies (see Annex V to regulation (EU) No 305/2011).

5 Technical details necessary for the implementation of the AVCP system, as provided in the applicable European Assessment Document (EAD)

Technical details necessary for the implementation of the AVCP system are laid down in the control plan deposited in Instytut Techniki Budowlanej.

For type testing the results of the tests performed as part of the assessment for the European Technical Assessment shall be used unless there are changes in the production line or plant. In such cases the necessary type testing has to be agreed between Instytut Techniki Budowlanej and the notified body.

Issued in Warsaw on 22/12/2025 by Instytut Techniki Budowlanej



Anna Panek, MSc
Deputy Director of ITB

Additional provisions

- INTU FR COLLAR and INTU FR COLLAR L shall be either fixed on both sides of the wall or fixed at the bottom of the floor (for details see Annex F).
- INTU FR COLLAR, INTU FR COLLAR L shall be fixed to the wall or the floor by steel fasteners with dimensions of min. M6x40 mm. Different variants of INTU FR COLLAR, INTU FR COLLAR L housings and minimal number of fixing brackets are given in Annex B.
- The INTU FR SLEEVE shall be placed in the separating element: in the centre of the wall thickness or in the distance of 10 mm from the bottom of the floor (for details see Annex F).
- Services are placed in angle 90° to the supporting construction.
- The minimum distance between adjacent penetration seals (between adjacent collars) shall be 100 mm.
- Pipes shall be supported at maximum 400 mm away from both faces of the wall constructions and from the upper face of floor constructions.

Combustible pipes

- Classifications given in Annex C, Annex D and Annex E are valid for specific pipes made of:
 - PVC-U according to EN 1329-1, EN 1453-1 or EN 1452-1,
 - PVC-C according to EN 1566-1,
 - PE according to EN 12201-2, EN 1519-1 and EN 12666-1,
 - PE-HD according to EN 1519-1 or EN 12666-1,
 - ABS according to EN 1455-1,
 - SAN + PVC according to EN 1565-1,
 - PP according to EN 1451-1,
 - PE-X/Al/PE-X according to EN ISO 21003-2,
 - PP-R/Al/PP-R according to EN ISO 15874-1 and EN ISO 15874-2,
 - PP-R/PP-R-GF/PP-R according to EN ISO 15874-1 and EN ISO 15874-2,
 - PE-RT according to EN ISO 21003-1,
 - PE-RT/Al/PE-RT according to EN ISO 21003-2,
 - PE-X according to EN ISO 21003-1,
 - PP-R according to EN ISO 15874-2,
 according to tables in Annex C, Annex D and Annex E.

Metal pipes

- Classifications given in Annex C, Annex D and Annex E for steel and copper pipes are also valid for other metal pipes with:
 - thermal conductivity lower than respectively steel or copper, and
 - melting point at least equal to respectively steel or copper, or greater than:
 - 739 °C for the fire resistance class EI 15 and E 15,
 - 782 °C for the fire resistance class EI 20 and E 20,
 - 843 °C for the fire resistance class EI 30 and E 30,
 - 903 °C for the fire resistance class EI 45 and E 45,
 - 946 °C for the fire resistance class EI 60 and E 60,
 - 1006 °C for the fire resistance class EI 90 and E 90,
 - 1049 °C for the fire resistance class EI 120 and E 120,
 - 1109 °C for the fire resistance class EI 180 and E 180,
 - 1153 °C for the fire resistance class EI 240 and E 240.

Classifications given in Annex C, Annex D and Annex E for insulated pipes is valid for pipes with sustained and continued insulation made of flexible elastomeric foam (FEF) (for details see clause 1 of ETA) and does not cover locally insulated or non-insulated pipes. The thickness, density and reaction to fire of insulation shall remain in accordance with ETA provisions.

INTU FR COLLAR, INTU FR COLLAR L, INTU FR SLEEVE	Annex A of European Technical Assessment ETA-19/0844
Additional provisions	

dimensions in mm

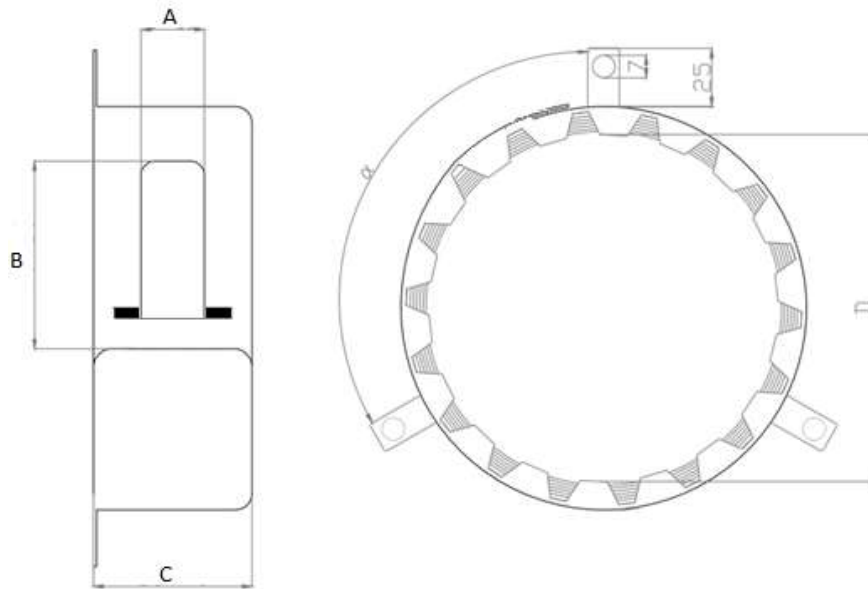
Note

For collars with $D < 200$ mm: collar casing made of steel sheet thickness of 0,5 mm with powder coating thickness of $0,1 \text{ mm} \pm 15\%$ or stainless steel sheet thickness of 0,5 mm.

For collars with $D \geq 200$ mm: collar casing made of steel sheet thickness of 1,0 mm with powder coating thickness of $0,1 \text{ mm} \pm 15\%$ or stainless steel sheet thickness of 1,0 mm.

D (pipe diameter with insulation)	Number of fixing brackets	α	A	B	C
≤ 50	2	180	8	20	31
$50 > D \geq 75$	2	180	8	20	31
$75 > D \geq 90$	3	120	8	25	31
$90 > D \geq 110$	3	120	8	25	31
$110 > D \geq 125$	4	90	8	35	41
$125 > D \geq 160$	4	90	8	35	41
$160 > D \geq 200$	4	90	8	35	61
$200 > D \geq 315$	5	72	2 x 8	35	220
$315 > D \geq 355$	6	60	2 x 8	35	220

Fig. B1. Details of INTU FR COLLAR
INTU FR COLLAR, INTU FR COLLAR L, INTU FR SLEEVE
Housing variants of collars
Annex B1
 of European
 Technical Assessment
 ETA-19/0844

dimensions in mm

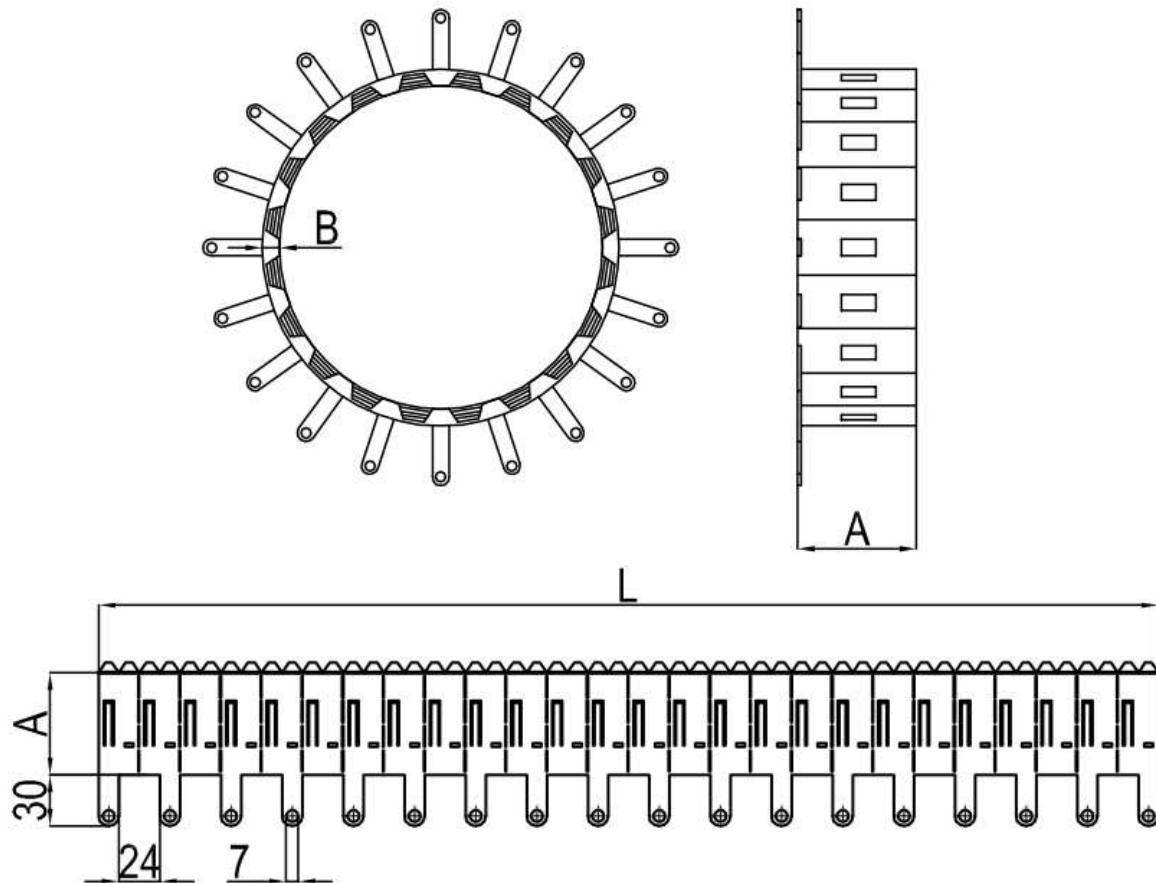

Note

Collar casing made of steel sheet thickness of 0,5 mm with powder coating thickness of 0,1 mm ± 15%, or stainless steel 0,5 mm.

Pipe diameter with insulation	Number of fixing brackets	A	B
≤ 75 mm	2	60	6
76 – 110 mm	3		
111 – 200 mm	4		
201 – 315 mm	5		
316 – 355 mm	6		

Fig. B2. Details of INTU FR COLLAR L

INTU FR COLLAR, INTU FR COLLAR L, INTU FR SLEEVE	Annex B2 of European Technical Assessment ETA-19/0844
Housing variants of collars	

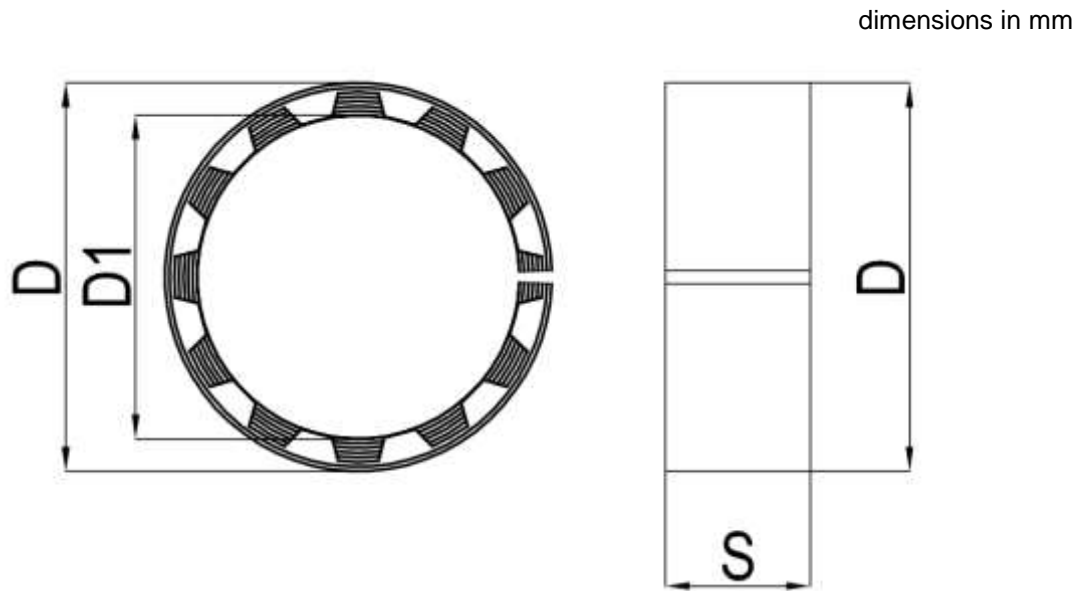
Note

Collar casing made of steel sheet thickness of 0,5 mm with powder coating thickness of 0,1 mm \pm 15% or stainless steel sheet thickness of 0,5 mm.

D	D1	Pipe diameter	Number of layers of intumescent liner (with thickness of 2,0 mm)	S (width of intumescent liner)
152	123	160	6	60
120	96	125	5	60
106	89	110	3	60

Fig. B3. Details of INTU FR SLEEVE

INTU FR COLLAR, INTU FR COLLAR L, INTU FR SLEEVE

Housing variants of collars

Annex B3
of European
Technical Assessment
ETA-19/0844

Table C1. Fire resistance class of PE-HD, PE, ABS or SAN + PVC pipes penetration seal in flexible or rigid wall thickness of: $100 \text{ mm} \leq t < 125 \text{ mm}$, made with use of INTU FR COLLAR in accordance with fig. F1 and F2 in Annex F:

Pipe diameter [mm]	Pipe wall thickness [mm]	Insulation thickness [mm]	Intumescent material width x thickness [mm]	Fire resistance class
$D \leq 32$	2,0	–	30 x 4,0	EI 120 – U/C EI 120 – C/C EI 120 – C/C
	2,1 – 6,8	–	30 x 6,0	EI 60 / E 90 – U/C EI 60 / E 90 – C/C EI 60 / E 90 – C/C
$32 < D \leq 40$	2,2 – 6,8	–	30 x 6,0	
$40 < D \leq 50$	2,5 – 6,8	–	30 x 6,0	
$50 < D \leq 55$	2,6 – 6,8	–	30 x 6,0	
$55 < D \leq 63$	2,8 – 6,8	–	30 x 6,0	
$63 < D \leq 75$	3,0 – 6,8	–	30 x 6,0	
$75 < D \leq 90$	3,6 – 8,2	–	30 x 8,0	
$90 < D \leq 110$	4,2 – 10,0	–	30 x 10,0	EI 60 – U/C EI 60 – C/C EI 60 – C/C
$110 < D \leq 125$	4,8 – 9,9	–	40 x 14,0	
$125 < D \leq 160$	6,2 – 9,5	–	40 x 18,0	

Classifications given above for specific intumescent material dimensions are also valid for pipes with smaller pipe diameter and the same pipe wall thickness range.

INTU FR COLLAR

Penetration seals made with use of INTU FR COLLAR
Plastic pipes without insulation penetration seals in flexible or rigid wall

Annex C1
of European
Technical Assessment
ETA-19/0844

Table C2. Fire resistance class of PP pipes penetration seal in flexible or rigid wall thickness of: $100 \text{ mm} \leq t < 125 \text{ mm}$, made with use of INTU FR COLLAR in accordance with fig. F1 and F2 in Annex F:

Pipe diameter [mm]	Pipe wall thickness [mm]	Insulation thickness [mm]	Intumescent material width x thickness [mm]	Fire resistance class
$D \leq 32$	1,8	–	30 x 4,0	EI 90 – U/C EI 90 – C/C
	1,9 – 12,5	–	30 x 6,0	EI 60 – U/C EI 60 – C/C
$32 < D \leq 40$	1,8	–	30 x 4,0	EI 90 – U/C EI 90 – C/C
	1,9 – 12,5	–	30 x 6,0	EI 60 – U/C EI 60 – C/C
$40 < D \leq 50$	1,8	–	30 x 4,0	EI 90 – U/C EI 90 – C/C
	1,9 – 12,5	–	30 x 6,0	EI 60 – U/C EI 60 – C/C
$50 < D \leq 55$	1,9 – 12,5	–	30 x 6,0	
$55 < D \leq 63$	1,9 – 12,5	–	30 x 6,0	
$63 < D \leq 75$	1,9 – 12,5	–	30 x 6,0	
$75 < D \leq 90$	2,3 – 15,1	–	30 x 8,0	
$90 < D \leq 110$	2,7 – 18,4	–	30 x 10,0	
$110 < D \leq 125$	4,1 – 15,1	–	40 x 14,0	
$125 < D \leq 160$	7,3	–	40 x 18,0	

Classifications given above for specific intumescent material dimensions are also valid for pipes with smaller pipe diameter and the same pipe wall thickness range.

INTU FR COLLAR

Penetration seals made with use of INTU FR COLLAR
Plastic pipes without insulation penetration seals in flexible or rigid wall

Annex C2
of European
Technical Assessment
ETA-19/0844

Table C3. Fire resistance class of PVC-U or PVC-C pipes penetration seal in flexible or rigid wall thickness of: $100 \text{ mm} \leq t < 125 \text{ mm}$, made with use of INTU FR COLLAR in accordance with fig. F1 and F2 in Annex F:

Pipe diameter [mm]	Pipe wall thickness [mm]	Insulation thickness [mm]	Intumescent material width x thickness [mm]	Fire resistance class	
$D \leq 32$	1,8	–	30 x 4,0	EI 120 – U/C EI 120 – C/C	
	1,9 – 3,6	–	30 x 6,0		
$32 < D \leq 40$	1,8	–	30 x 4,0		
	1,9 – 3,6	–	30 x 6,0		
$40 < D \leq 50$	1,8	–	30 x 4,0		
	1,9 – 3,6	–	30 x 6,0		
$50 < D \leq 55$	1,9 – 3,5	–	30 x 6,0		EI 90 – U/C EI 90 – C/C
	3,6	–	30 x 6,0		EI 120 – U/C EI 120 – C/C
$55 < D \leq 63$	1,9 – 3,5	–	30 x 6,0		EI 90 – U/C EI 90 – C/C
	3,6	–	30 x 6,0		EI 120 – U/C EI 120 – C/C
$63 < D \leq 75$	1,9 – 3,5	–	30 x 6,0	EI 90 – U/C EI 90 – C/C	
	3,6	–	30 x 6,0	EI 120 – U/C EI 120 – C/C	
$75 < D \leq 90$	2,1 – 2,2	–	30 x 8,0	EI 90 – U/C EI 90 – C/C	
	2,3 – 3,9	–	30 x 8,0	EI 60 – U/C EI 60 – C/C	
$90 < D \leq 110$	2,2	–	30 x 10,0	EI 90 – U/C EI 90 – C/C	
	2,3 – 4,2	–	30 x 10,0	EI 60 – U/C EI 60 – C/C	
$110 < D \leq 125$	2,5 – 3,2	–	40 x 14,0	EI 90 – U/C	
$125 < D \leq 160$	3,2 – 6,2	–	40 x 18,0	EI 90 – C/C	

Classifications given above for specific intumescent material dimensions are also valid for pipes with smaller pipe diameter and the same pipe wall thickness range.

INTU FR COLLAR

Penetration seals made with use of INTU FR COLLAR
Plastic pipes without insulation penetration seals in flexible or rigid wall

Annex C3
of European
Technical Assessment
ETA-19/0844

Table C4. Fire resistance class of PE-HD, PE, ABS or SAN + PVC pipes penetration seal in flexible or rigid wall thickness of: $125 \text{ mm} \leq t < 150 \text{ mm}$, made with use of INTU FR COLLAR in accordance with fig. F1 and F2 in Annex F:

Pipe diameter [mm]	Pipe wall thickness [mm]	Insulation thickness [mm]	Intumescent material width x thickness [mm]	Fire resistance class
$D \leq 32$	2,0 – 4,6	–	30 x 4,0	EI 120 – U/C EI 120 – C/C
$32 < D \leq 40$	2,2 – 6,8	–	30 x 6,0	EI 90 – U/C EI 90 – C/C
$40 < D \leq 50$	2,5 – 6,8	–	30 x 6,0	
$50 < D \leq 55$	2,6 – 6,8	–	30 x 6,0	
$55 < D \leq 63$	2,8 – 6,8	–	30 x 6,0	
$63 < D \leq 75$	3,0 – 6,8	–	30 x 6,0	
$75 < D \leq 90$	3,6 – 4,2	–	30 x 8,0	
	4,3 – 8,2	–	30 x 8,0	EI 60 – U/C EI 60 – C/C
$90 < D \leq 110$	4,2	–	30 x 10,0	EI 90 – U/C EI 90 – C/C
	4,3 – 10,0	–	30 x 10,0	EI 60 – U/C EI 60 – C/C
$110 < D \leq 125$	4,8 – 9,9	–	40 x 14,0	EI 60 – U/C EI 60 – C/C
$125 < D \leq 160$	6,2	–	40 x 18,0	EI 120 – U/C EI 120 – C/C
	6,3 – 9,5	–	40 x 18,0	EI 60 – U/C EI 60 – C/C

Classifications given above for specific intumescent material dimensions are also valid for pipes with smaller pipe diameter and the same pipe wall thickness range.

INTU FR COLLAR

Penetration seals made with use of INTU FR COLLAR
Plastic pipes without insulation penetration seals in flexible or rigid wall

Annex C4
of European
Technical Assessment
ETA-19/0844

Table C5. Fire resistance class of PP pipes penetration seal in flexible or rigid wall thickness of: $125 \text{ mm} \leq t < 150 \text{ mm}$, made with use of INTU FR COLLAR in accordance with fig. F1 and F2 in Annex F:

Pipe diameter [mm]	Pipe wall thickness [mm]	Insulation thickness [mm]	Intumescent material width x thickness [mm]	Fire resistance class
$D \leq 32$	1,8 – 8,3	–	30 x 4,0	EI 120 – U/C EI 120 – C/C
$32 < D \leq 40$	1,8 – 8,3	–	30 x 4,0	
$40 < D \leq 50$	1,8 – 8,3	–	30 x 4,0	
$50 < D \leq 55$	1,9 – 12,5	–	30 x 6,0	
$55 < D \leq 63$	1,9 – 12,5	–	30 x 6,0	
$63 < D \leq 75$	1,9 – 12,5	–	30 x 6,0	
$75 < D \leq 90$	2,3 – 8,3	–	30 x 8,0	EI 90 / E 120 – U/C EI 90 / E 120 – C/C
	8,4 – 15,1	–	30 x 8,0	
$90 < D \leq 110$	2,7	–	30 x 10,0	EI 120 – U/C EI 120 – C/C
	2,8 – 18,4	–	30 x 10,0	EI 90 / E 120 – U/C EI 90 / E 120 – C/C
$110 < D \leq 125$	4,1 – 15,1	–	40 x 14,0	EI 60 / E 90 – U/C
$125 < D \leq 160$	7,3	–	40 x 18,0	EI 60 / E 90 – C/C

Classifications given above for specific intumescent material dimensions are also valid for pipes with smaller pipe diameter and the same pipe wall thickness range.

INTU FR COLLAR

Penetration seals made with use of INTU FR COLLAR
Plastic pipes without insulation penetration seals in flexible or rigid wall

Annex C5
of European
Technical Assessment
ETA-19/0844

Table C6. Fire resistance class of PVC-U or PVC-C pipes penetration seal in flexible or rigid wall thickness of: $125 \text{ mm} \leq t < 150 \text{ mm}$, made with use of INTU FR COLLAR in accordance with fig. F1 and F2 in Annex F:

Pipe diameter [mm]	Pipe wall thickness [mm]	Insulation thickness [mm]	Intumescent material width x thickness [mm]	Fire resistance class
$D \leq 32$	1,8 – 3,6	–	30 x 4,0	EI 120 – U/C EI 120 – C/C
$32 < D \leq 40$	1,8 – 3,6	–	30 x 4,0	
$40 < D \leq 50$	1,8 – 3,6	–	30 x 4,0	
$50 < D \leq 55$	1,9 – 3,6	–	30 x 6,0	
$55 < D \leq 63$	1,9 – 3,6	–	30 x 6,0	
$63 < D \leq 75$	1,9 – 3,6	–	30 x 6,0	
$75 < D \leq 90$	2,1 – 3,9	–	30 x 8,0	
$90 < D \leq 110$	2,2 – 4,2	–	30 x 10,0	
	2,5 – 3,9	–	40 x 14,0	
$110 < D \leq 125$	4,0 – 4,8	–	40 x 14,0	EI 90 / E 120 – U/C EI 90 / E 120 – C/C
$125 < D \leq 160$	3,2	–	40 x 18,0	EI 120 – U/C EI 120 – C/C
	3,3 – 6,2	–	40 x 18,0	EI 90 / E 120 – U/C EI 90 / E 120 – C/C

Classifications given above for specific intumescent material dimensions are also valid for pipes with smaller pipe diameter and the same pipe wall thickness range.

INTU FR COLLAR

Penetration seals made with use of INTU FR COLLAR
Plastic pipes without insulation penetration seals in flexible or rigid wall

Annex C6
of European
Technical Assessment
ETA-19/0844

Table C7. Fire resistance class of PE-HD, PE, ABS or SAN + PVC pipes penetration seal in rigid wall thickness of: $t \geq 150$ mm, made with use of INTU FR COLLAR in accordance with fig. F2 in Annex F:

Pipe diameter [mm]	Pipe wall thickness [mm]	Insulation thickness [mm]	Intumescent material width x thickness [mm]	Fire resistance class
$D \leq 32$	2,0	–	30 x 4,0	EI 240 – U/C EI 240 – C/C
	2,1 – 4,8	–	30 x 4,0	EI 120 – U/C EI 120 – C/C
$32 < D \leq 40$	2,5 – 4,8	–	30 x 4,0	
$40 < D \leq 50$	3,0 – 4,8	–	30 x 4,0	
$50 < D \leq 55$	3,0 – 3,5	–	30 x 6,0	EI 90 – U/C EI 90 – C/C
	3,6	–	30 x 6,0	EI 240 – U/C EI 240 – C/C
	3,7 – 6,8	–	30 x 6,0	EI 120 – U/C EI 120 – C/C
$55 < D \leq 63$	3,0 – 3,5	–	30 x 6,0	EI 90 – U/C EI 90 – C/C
	3,6	–	30 x 6,0	EI 240 – U/C EI 240 – C/C
	3,7 – 6,8	–	30 x 6,0	EI 120 – U/C EI 120 – C/C
$63 < D \leq 75$	3,0 – 3,5	–	30 x 6,0	EI 90 – U/C EI 90 – C/C
	3,6	–	30 x 6,0	EI 240 – U/C EI 240 – C/C
	3,7 – 6,8	–	30 x 6,0	EI 120 – U/C EI 120 – C/C
$75 < D \leq 90$	3,6 – 3,8	–	30 x 8,0	EI 90 – U/C EI 90 – C/C
	3,9 – 8,2	–	30 x 8,0	EI 120 – U/C EI 120 – C/C
$90 < D \leq 110$	4,2 – 9,9	–	30 x 10,0	
	10,0	–	30 x 10,0	EI 240 – U/C EI 240 – C/C
$110 < D \leq 125$	4,8 – 6,1	–	40 x 14,0	EI 90 – U/C EI 90 – C/C
	6,2 – 9,0	–	40 x 14,0	EI 120 – U/C EI 120 – C/C
$125 < D \leq 160$	6,2 – 9,4	–	40 x 18,0	
	9,5	–	40 x 18,0	EI 180 – U/C EI 180 – C/C
$160 < D \leq 170$	6,6 – 9,1	–	50 x 20,0	EI 60 – U/C EI 60 – C/C
$170 < D \leq 185$	7,2 – 8,4	–	50 x 20,0	
$185 < D \leq 200$	7,7	–	50 x 20,0	

Classifications given above for specific intumescent material dimensions are also valid for pipes with smaller pipe diameter and the same pipe wall thickness range.

INTU FR COLLAR

Penetration seals made with use of INTU FR COLLAR
Plastic pipes without insulation penetration seals in rigid wall

Annex C7
of European
Technical Assessment
ETA-19/0844

Table C8. Fire resistance class of PP pipes penetration seal in rigid wall thickness of: $t \geq 150$ mm, made with use of INTU FR COLLAR in accordance with fig. F2 in Annex F:

Pipe diameter [mm]	Pipe wall thickness [mm]	Insulation thickness [mm]	Intumescent material width x thickness [mm]	Fire resistance class
D ≤ 32	1,8	–	30 x 4,0	EI 240 – U/C EI 240 – C/C
	1,9 – 8,3	–	30 x 4,0	EI 120 – U/C EI 120 – C/C
32 < D ≤ 40	1,8	–	30 x 4,0	EI 240 – U/C EI 240 – C/C
	1,9 – 8,3	–	30 x 4,0	EI 120 – U/C EI 120 – C/C
40 < D ≤ 50	1,8	–	30 x 4,0	EI 240 – U/C EI 240 – C/C
	1,9 – 8,3	–	30 x 4,0	EI 120 – U/C EI 120 – C/C
50 < D ≤ 55	1,9 – 12,5	–	30 x 6,0	
55 < D ≤ 63	1,9 – 12,5	–	30 x 6,0	
63 < D ≤ 75	1,9 – 12,5	–	30 x 6,0	
75 < D ≤ 90	2,3 – 15,1	–	30 x 8,0	
90 < D ≤ 110	2,7 – 18,3	–	30 x 10,0	
	18,4	–	30 x 10,0	
110 < D ≤ 125	3,8 – 14,8	–	40 x 14,0	EI 120 – U/C EI 120 – C/C
	14,9 – 15,2	–	40 x 14,0	EI 60 – U/C EI 60 – C/C
125 < D ≤ 160	6,2	–	40 x 18,0	EI 180 – U/C EI 180 – C/C
	6,3 – 7,7	–	40 x 18,0	EI 60 – U/C
160 < D ≤ 170	6,6 – 7,6	–	60 x 20,0	EI 60 – C/C
	7,7	–	60 x 20,0	EI 180 – U/C EI 180 – C/C
170 < D ≤ 185	7,2 – 7,6	–	60 x 20,0	EI 60 – U/C EI 60 – C/C
	7,7	–	60 x 20,0	EI 180 – U/C
185 < D ≤ 200	7,7	–	60 x 20,0	EI 180 – C/C

Classifications given above for specific intumescent material dimensions are also valid for pipes with smaller pipe diameter and the same pipe wall thickness range.

INTU FR COLLAR

Penetration seals made with use of INTU FR COLLAR
Plastic pipes without insulation penetration seals in rigid wall

Annex C8
of European
Technical Assessment
ETA-19/0844

Table C9. Fire resistance class of PVC-U or PVC-C pipes penetration seal in rigid wall thickness of: $t \geq 150$ mm, made with use of INTU FR COLLAR in accordance with fig. F2 in Annex F:

Pipe diameter [mm]	Pipe wall thickness [mm]	Insulation thickness [mm]	Intumescent material width x thickness [mm]	Fire resistance class
$D \leq 32$	1,8 – 3,6	–	30 x 4,0	EI 240 – U/C EI 240 – C/C
$32 < D \leq 40$	1,8 – 3,6	–	30 x 4,0	
$40 < D \leq 50$	1,8 – 3,6	–	30 x 4,0	
$50 < D \leq 55$	1,9 – 3,6	–	30 x 6,0	EI 180 – U/C EI 180 – C/C
$55 < D \leq 63$	1,9 – 3,6	–	30 x 6,0	
$63 < D \leq 75$	1,9 – 3,6	–	30 x 6,0	
$75 < D \leq 90$	2,1 – 3,9	–	30 x 8,0	
$90 < D \leq 110$	2,2	–	30 x 10,0	EI 240 – U/C EI 240 – C/C
	2,3 – 4,2	–	30 x 10,0	EI 180 – U/C EI 180 – C/C
$110 < D \leq 125$	2,5 – 4,8	–	40 x 14,0	EI 120 – U/C EI 120 – C/C
$125 < D \leq 160$	3,2	–	40 x 18,0	EI 240 – U/C EI 240 – C/C
	3,3 – 6,2	–	40 x 18,0	EI 120 / E 180 – U/C EI 120 / E 180 – C/C
$160 < D \leq 170$	3,4 – 5,4	–	50 x 20,0	EI 90 – U/C EI 90 – C/C
	5,5	–	50 x 20,0	EI 180 / E 240 – U/C EI 180 / E 240 – C/C
	5,6 – 7,7	–	60 x 20,0	EI 180 – U/C EI 180 – C/C
$170 < D \leq 185$	3,7 – 5,4	–	50 x 20,0	EI 90 – U/C EI 90 – C/C
	5,5	–	50 x 20,0	EI 180 / E 240 – U/C EI 180 / E 240 – C/C
	5,6 – 7,7	–	60 x 20,0	EI 180 – U/C EI 180 – C/C
$185 < D \leq 200$	3,9 – 5,4	–	50 x 20,0	EI 90 – U/C EI 90 – C/C
	5,5	–	50 x 20,0	EI 180 / E 240 – U/C EI 180 / E 240 – C/C
	5,6 – 7,7	–	60 x 20,0	EI 180 – U/C EI 180 – C/C
$200 < D \leq 225$	4,8 – 8,0	–	(2 x 75) x 30,0	EI 120 – U/C EI 120 – C/C
$225 < D \leq 250$	5,7 – 8,0	–	(2 x 75) x 30,0	
$250 < D \leq 275$	6,6 – 8,0	–	(2 x 75) x 30,0	
$275 < D \leq 300$	7,5 – 8,0	–	(2 x 75) x 30,0	
$300 < D \leq 315$	8,0	–	(2 x 75) x 30,0	

Classifications given above for specific intumescent material dimensions are also valid for pipes with smaller pipe diameter and the same pipe wall thickness range.

INTU FR COLLAR

Penetration seals made with use of INTU FR COLLAR
Plastic pipes without insulation penetration seals in rigid wall

Annex C9
of European
Technical Assessment
ETA-19/0844

Table C10. Fire resistance class of PE-RT pipes penetration seal in rigid wall thickness of: $t \geq 150$ mm, made with use of INTU FR COLLAR in accordance with fig. F2 in Annex F:

Pipe diameter [mm]	Pipe wall thickness [mm]	Insulation thickness [mm]	Intumescent material width x thickness [mm]	Fire resistance class
$D \leq 20$	2,0	–	30 x 4,0	EI 240 – U/C EI 240 – C/C

Table C11. Fire resistance class of PE-X pipes penetration seal in rigid wall thickness of: $t \geq 150$ mm, made with use of INTU FR COLLAR in accordance with fig. F2 in Annex F:

Pipe diameter [mm]	Pipe wall thickness [mm]	Insulation thickness [mm]	Intumescent material width x thickness [mm]	Fire resistance class
$D \leq 20$	2,0	–	30 x 4,0	EI 240 – U/C EI 240 – C/C
$D \leq 20$	2,1 – 7,5	–	30 x 6,0	EI 120 / E 240 – U/C EI 120 / E 240 – C/C
$20 < D \leq 75$	7,5	–	30 x 6,0	

Table C12. Fire resistance class of PP-R/Al/PP-R pipes penetration seal in rigid wall thickness of: $t \geq 150$ mm, made with use of INTU FR COLLAR in accordance with fig. F2 in Annex F:

Pipe diameter [mm]	Pipe wall thickness [mm]	Insulation thickness [mm]	Intumescent material width x thickness [mm]	Fire resistance class
$D \leq 20$	3,4	–	30 x 4,0	EI 180 / E 240 – U/C EI 180 / E 240 – C/C
	3,5 – 18,3	–	30 x 10,0	EI 90 / E 180 – U/C
$20 < D \leq 110$	18,3	–	30 x 10,0	EI 90 / E 180 – C/C

Table C13. Fire resistance class of PP-R/PP-R-GF/PP-R pipes penetration seal in rigid wall thickness of: $t \geq 150$ mm, made with use of INTU FR COLLAR in accordance with fig. F2 in Annex F:

Pipe diameter [mm]	Pipe wall thickness [mm]	Insulation thickness [mm]	Intumescent material width x thickness [mm]	Fire resistance class
$D \leq 20$	3,4	–	30 x 4,0	EI 240 – U/C EI 240 – C/C
	3,5 – 18,3	–	30 x 10,0	EI 90 / E 120 – U/C
$20 < D \leq 110$	18,3	–	30 x 10,0	EI 90 / E 120 – C/C

Classifications given above for specific intumescent material dimensions are also valid for pipes with smaller pipe diameter and the same pipe wall thickness range.

INTU FR COLLAR	Annex C10 of European Technical Assessment ETA-19/0844
Penetration seals made with use of INTU FR COLLAR Plastic pipes without insulation penetration seals in rigid wall	

Table C14. Fire resistance class of bundle of max. 3 plastic pipes (max. 3 x PE, $D \leq 32$ mm x $t = 2,0$ mm) penetration seal in rigid wall thickness of: $t \geq 150$ mm, made with use of INTU FR COLLAR with intumescent material width x thickness 30 x 4,0 mm in accordance with fig. F2 in Annex F:

Fire resistance class:
EI 240 – C/U
EI 240 – C/C

Table C15. Fire resistance class of bundle of max. 3 plastic pipes (max. 3 x PE-HD, PE, ABS or SAN + PVC, $D \leq 32$ mm x $t = 2,0$ mm) penetration seal in rigid wall thickness of: $t \geq 150$ mm, made with use of INTU FR COLLAR with intumescent material width x thickness 30 x 4,0 mm in accordance with fig. F2 in Annex F:

Fire resistance class:
EI 120 / E 180 – C/U
EI 120 / E 180 – C/C

Table C16. Fire resistance class of bundle of max. 3 plastic pipes (max. 2 x PE-HD, PE, ABS or SAN + PVC, $D \leq 32$ mm x $t = 2,0$ mm + max. 1 x PVC-U or PVC-C, $D \leq 50$ mm x $t = 1,8$ mm) penetration seal in rigid wall thickness of: $t \geq 150$ mm, made with use of INTU FR COLLAR with intumescent material width x thickness 30 x 4,0 mm in accordance with fig. F2 in Annex F:

Fire resistance class:
EI 120 – C/U
EI 120 – C/C

INTU FR COLLAR

Penetration seals made with use of INTU FR COLLAR
 Plastic pipes bundle penetration seals in rigid wall

Annex C11
 of European
 Technical Assessment
 ETA-19/0844

Table C17. Fire resistance class of PE-HD, PE, ABS or SAN + PVC pipes penetration seal in rigid floor thickness of: $t \geq 150$ mm, made with use of INTU FR COLLAR in accordance with fig. F5 in Annex F:

Pipe diameter [mm]	Pipe wall thickness [mm]	Insulation thickness [mm]	Intumescent material width x thickness [mm]	Fire resistance class
$D \leq 32$	1,8 – 4,8	–	30 x 4,0	EI 240 – U/C EI 240 – C/C
$32 < D \leq 40$	2,4 – 4,8	–	30 x 4,0	
$40 < D \leq 50$	3,0 – 4,8	–	30 x 4,0	
$50 < D \leq 55$	2,8 – 3,5	–	30 x 6,0	EI 180 – U/C EI 180 – C/C
	3,6	–	30 x 6,0	EI 240 – U/C EI 240 – C/C
	3,7 – 6,8	–	30 x 6,0	EI 180 – U/C EI 180 – C/C
$55 < D \leq 63$	3,1 – 3,5	–	30 x 6,0	EI 240 – U/C EI 240 – C/C
	3,6	–	30 x 6,0	EI 180 – U/C EI 180 – C/C
	3,7 – 6,8	–	30 x 6,0	EI 240 – U/C EI 240 – C/C
$63 < D \leq 75$	3,6	–	30 x 6,0	EI 120 – U/C EI 120 – C/C
	3,7 – 6,8	–	30 x 6,0	EI 180 – U/C EI 180 – C/C
$75 < D \leq 90$	3,9 – 8,2	–	30 x 8,0	EI 120 – U/C EI 120 – C/C
$90 < D \leq 110$	4,2 – 10,0	–	30 x 10,0	
$110 < D \leq 125$	4,8 – 9,9	–	40 x 14,0	
$125 < D \leq 160$	6,2 – 9,4	–	40 x 18,0	EI 180 / E 240 – U/C EI 180 / E 240 – C/C
	9,5	–	40 x 18,0	
$160 < D \leq 170$	6,6 – 9,1	–	60 x 20,0	EI 120 – U/C EI 120 – C/C
	9,2 – 11,0	–	60 x 20,0	EI 90 – U/C EI 90 – C/C
	11,1 – 11,3	–	60 x 20,0	EI 60 – U/C EI 60 – C/C
$170 < D \leq 185$	7,2 – 8,4	–	60 x 20,0	EI 120 – U/C EI 120 – C/C
	8,5 – 11,0	–	60 x 20,0	EI 90 – U/C EI 90 – C/C
	11,1 – 11,3	–	60 x 20,0	EI 60 – U/C EI 60 – C/C
$185 < D \leq 200$	7,7	–	60 x 20,0	EI 120 – U/C EI 120 – C/C
	7,8 – 11,0	–	60 x 20,0	EI 90 – U/C EI 90 – C/C
	11,1 – 11,3	–	60 x 20,0	EI 60 – U/C EI 60 – C/C

Classifications given above for specific intumescent material dimensions are also valid for pipes with smaller pipe diameter and the same pipe wall thickness range.

INTU FR COLLAR	Annex C12 of European Technical Assessment ETA-19/0844
Penetration seals made with use of INTU FR COLLAR Plastic pipes without insulation penetration seals in rigid floor	

Table C18. Fire resistance class of PP pipes penetration seal in rigid floor thickness of: $t \geq 150$ mm, made with use of INTU FR COLLAR in accordance with fig. F5 in Annex F:

Pipe diameter [mm]	Pipe wall thickness [mm]	Insulation thickness [mm]	Intumescent material width x thickness [mm]	Fire resistance class
$D \leq 32$	1,8 – 8,3	–	30 x 4,0	EI 240 – U/C EI 240 – C/C
$32 < D \leq 40$	1,8 – 8,3	–	30 x 4,0	
$40 < D \leq 50$	1,8 – 8,3	–	30 x 4,0	
$50 < D \leq 55$	1,9	–	30 x 6,0	EI 180 – U/C EI 180 – C/C
	2,0 – 12,5	–	30 x 6,0	EI 120 – U/C EI 120 – C/C
$55 < D \leq 63$	1,9	–	30 x 6,0	EI 180 – U/C EI 180 – C/C
	2,0 – 12,5	–	30 x 6,0	EI 120 – U/C EI 120 – C/C
$63 < D \leq 75$	1,9	–	30 x 6,0	EI 180 – U/C EI 180 – C/C
	2,0 – 12,5	–	30 x 6,0	EI 120 – U/C EI 120 – C/C
$75 < D \leq 90$	2,3 – 15,1	–	30 x 8,0	EI 180 – U/C EI 120 – C/C
$90 < D \leq 110$	2,7	–	30 x 10,0	EI 180 – U/C EI 180 – C/C
	2,8 – 18,4	–	30 x 10,0	EI 120 – U/C EI 120 – C/C
$110 < D \leq 125$	3,8 – 15,1	–	40 x 14,0	
$125 < D \leq 160$	6,2 – 7,3	–	40 x 18,0	
$160 < D \leq 170$	6,3 – 6,5	–	60 x 20,0	EI 60 – U/C EI 60 – C/C
	6,6 – 7,4	–	60 x 20,0	EI 120 – U/C EI 120 – C/C
$170 < D \leq 185$	6,3 – 7,1	–	60 x 20,0	EI 60 – U/C EI 60 – C/C
	7,2 – 7,6	–	60 x 20,0	EI 120 – U/C EI 120 – C/C
$185 < D \leq 200$	6,3 – 7,6	–	60 x 20,0	EI 60 – U/C EI 60 – C/C
	7,7	–	60 x 20,0	EI 120 – U/C EI 120 – C/C

Classifications given above for specific intumescent material dimensions are also valid for pipes with smaller pipe diameter and the same pipe wall thickness range.

INTU FR COLLAR

Penetration seals made with use of INTU FR COLLAR
Plastic pipes without insulation penetration seals in rigid floor

Annex C13
of European
Technical Assessment
ETA-19/0844

Table C19. Fire resistance class of PVC-U or PVC-C pipes penetration seal in rigid floor thickness of: $t \geq 150$ mm, made with use of INTU FR COLLAR in accordance with fig. F5 in Annex F:

Pipe diameter [mm]	Pipe wall thickness [mm]	Insulation thickness [mm]	Intumescent material width x thickness [mm]	Fire resistance class
$D \leq 32$	1,8 – 2,5	–	30 x 4,0	EI 240 – U/C EI 240 – C/C
$32 < D \leq 40$	1,8 – 2,5	–	30 x 4,0	
$40 < D \leq 50$	1,8 – 2,5	–	30 x 4,0	
$50 < D \leq 55$	1,9	–	30 x 6,0	EI 180 – U/C EI 180 – C/C
	2,0 – 3,6	–	30 x 6,0	
$55 < D \leq 63$	1,9	–	30 x 6,0	EI 240 – U/C EI 240 – C/C
	2,0 – 3,6	–	30 x 6,0	EI 180 – U/C EI 180 – C/C
$63 < D \leq 75$	1,9	–	30 x 6,0	EI 240 – U/C EI 240 – C/C
	2,0 – 3,6	–	30 x 6,0	EI 180 – U/C EI 180 – C/C
$75 < D \leq 90$	2,1 – 3,1	–	30 x 8,0	EI 120 – U/C EI 120 – C/C
	3,2 – 4,2	–	30 x 8,0	EI 180 – U/C EI 180 – C/C
$90 < D \leq 110$	2,1 – 3,1	–	30 x 10,0	EI 120 – U/C EI 120 – C/C
	3,2 – 4,2	–	30 x 10,0	EI 180 – U/C EI 180 – C/C
$110 < D \leq 125$	2,5 – 3,1	–	40 x 14,0	EI 120 – U/C EI 120 – C/C
	3,2 – 7,7	–	40 x 14,0	EI 240 – U/C EI 240 – C/C
$125 < D \leq 160$	3,2 – 7,7	–	40 x 18,0	EI 120 – U/C EI 120 – C/C
$160 < D \leq 170$	3,4 – 7,7	–	60 x 20,0	
$170 < D \leq 185$	3,7 – 7,7	–	60 x 20,0	
$185 < D \leq 200$	3,9 – 7,7	–	60 x 20,0	
$200 < D \leq 225$	4,8 – 8,0	–	(2 x 75) x 30,0	
	8,1 – 12,1	–	(2 x 75) x 30,0	EI 90 – U/C EI 90 – C/C
$225 < D \leq 250$	5,7 – 8,0	–	(2 x 75) x 30,0	EI 120 – U/C EI 120 – C/C
	8,1 – 12,1	–	(2 x 75) x 30,0	EI 90 – U/C EI 90 – C/C
$250 < D \leq 275$	6,6 – 8,0	–	(2 x 75) x 30,0	EI 120 – U/C EI 120 – C/C
	8,1 – 12,1	–	(2 x 75) x 30,0	EI 90 – U/C EI 90 – C/C
$275 < D \leq 300$	7,5 – 8,0	–	(2 x 75) x 30,0	EI 120 – U/C EI 120 – C/C
	8,1 – 12,1	–	(2 x 75) x 30,0	EI 90 – U/C EI 90 – C/C
$300 < D \leq 315$	8,0	–	(2 x 75) x 30,0	EI 120 – U/C EI 120 – C/C
	8,1 – 12,1	–	(2 x 75) x 30,0	EI 90 – U/C EI 90 – C/C
$315 < D \leq 325$	9,1 – 12,1	–	(2 x 75) x 30,0	
$325 < D \leq 355$	12,1	–	(2 x 75) x 30,0	

Classifications given above for specific intumescent material dimensions are also valid for pipes with smaller pipe diameter and the same pipe wall thickness range.

INTU FR COLLAR	Annex C14 of European Technical Assessment ETA-19/0844
Penetration seals made with use of INTU FR COLLAR Plastic pipes without insulation penetration seals in rigid floor	

Table C20. Fire resistance class of PE-RT/AI/PE-RT pipes penetration seal in rigid floor thickness of: $t \geq 150$ mm, made with use of INTU FR COLLAR in accordance with fig. F5 in Annex F:

Pipe diameter [mm]	Pipe wall thickness [mm]	Insulation thickness [mm]	Intumescent material width x thickness [mm]	Fire resistance class
$D \leq 20$	2,0	–	30 x 4,0	EI 240 – U/C EI 240 – C/C

Table C21. Fire resistance class of PE-X/AI/PE-X pipes penetration seal in rigid floor thickness of: $t \geq 150$ mm, made with use of INTU FR COLLAR in accordance with fig. F5 in Annex F:

Pipe diameter [mm]	Pipe wall thickness [mm]	Insulation thickness [mm]	Intumescent material width x thickness [mm]	Fire resistance class
$D \leq 20$	2,0	–	30 x 4,0	EI 240 – U/C EI 240 – C/C

Table C22. Fire resistance class of PP-R/AI/PP-R pipes penetration seal in rigid floor thickness of: $t \geq 150$ mm, made with use of INTU FR COLLAR in accordance with fig. F5 in Annex F:

Pipe diameter [mm]	Pipe wall thickness [mm]	Insulation thickness [mm]	Intumescent material width x thickness [mm]	Fire resistance class
$D \leq 20$	3,4	–	30 x 4,0	EI 240 – U/C EI 240 – C/C
	3,5 – 18,3	–	30 x 10,0	EI 120 – U/C
$20 < D \leq 110$	18,3	–	30 x 10,0	EI 120 – C/C

Classifications given above for specific intumescent material dimensions are also valid for pipes with smaller pipe diameter and the same pipe wall thickness range.

INTU FR COLLAR

Penetration seals made with use of INTU FR COLLAR
Plastic pipes without insulation penetration seals in rigid floor

Annex C15
of European
Technical Assessment
ETA-19/0844

Table D1. Fire resistance class of copper pipes with continuous flexible elastomeric foam (FEF) insulation penetration seal in rigid wall thickness of: $t \geq 150$ mm, made with use of INTU FR COLLAR L in accordance with fig. F3 in Annex F:

Pipe diameter [mm]	Pipe wall thickness [mm]	Insulation thickness [mm]	Intumescent material width x thickness [mm]	Fire resistance class
$D \leq 15,0$	$\geq 1,0$	9	60 x 2,0	EI 240 – C/U EI 240 – C/C
		10 – 19	60 x 4,0	EI 180 – C/U EI 180 – C/C
		20 – 22	60 x 4,0	
		23 – 36	60 x 6,0	
		37 – 49	60 x 8,0	
		50	60 x 8,0	
$15,0 < D \leq 42,4$	1,4 – 14,2	9	60 x 2,0	EI 60 / E 240 – C/U EI 60 / E 240 – C/C
		10 – 19	60 x 4,0	EI 45 – C/U EI 45 – C/C
		20 – 22	60 x 4,0	
		23 – 36	60 x 6,0	
		37 – 50	60 x 8,0	
		50	60 x 8,0	
$42,4 < D \leq 44,5$	1,4 – 14,2	9	60 x 2,0	EI 60 / E 240 – C/U EI 60 / E 240 – C/C
		10 – 19	60 x 4,0	EI 45 – C/U EI 45 – C/C
		20 – 22	60 x 4,0	
		23 – 36	60 x 6,0	
		37 – 50	60 x 8,0	
		50	60 x 8,0	
$44,5 < D \leq 54,0$	1,5 – 14,2	9	60 x 2,0	EI 60 / E 240 – C/U EI 60 / E 240 – C/C
		10 – 19	60 x 4,0	EI 45 – C/U EI 45 – C/C
		20 – 22	60 x 4,0	
		23 – 36	60 x 6,0	
		37 – 50	60 x 8,0	
		50	60 x 8,0	

Classifications given above for specific intumescent material dimensions are also valid for pipes with smaller pipe diameter and the same pipe wall thickness range.

INTU FR COLLAR L	Annex D1 of European Technical Assessment ETA-19/0844
Penetration seals made with use of INTU FR COLLAR L Metal pipes with insulation penetration seals in rigid wall	

Table D2. Fire resistance class of steel pipes with continuous flexible elastomeric foam (FEF) insulation penetration seal in rigid wall thickness of: $t \geq 150$ mm, made with use of INTU FR COLLAR L in accordance with fig. F3 in Annex F:

Pipe diameter [mm]	Pipe wall thickness [mm]	Insulation thickness [mm]	Intumescent material width x thickness [mm]	Fire resistance class
$D \leq 42,4$	2,0 – 14,2	9	60 x 2,0	EI 240 – C/U EI 240 – C/C
		10 – 11	60 x 4,0	EI 120 – C/U EI 120 – C/C
		12 – 20	60 x 4,0	
		21 – 22	60 x 4,0	
		23 – 28	60 x 6,0	
		29 – 34	60 x 6,0	
		35 – 39	60 x 8,0	
		40 – 45	60 x 8,0	
		46 – 49	60 x 8,0	
$42,4 < D \leq 44,5$	2,1 – 3,9	9	60 x 2,0	EI 90 / E 240 – C/U EI 90 / E 240 – C/C
		10 – 11	60 x 4,0	
		12 – 20	60 x 4,0	
		21 – 22	60 x 4,0	EI 120 / E 240 – C/U EI 120 / E 240 – C/C
		23	60 x 4,0	
		24 – 28	60 x 6,0	EI 90 / E 120 – C/U EI 90 / E 120 – C/C
		29 – 34	60 x 6,0	
		35 – 39	60 x 8,0	
		40 – 45	60 x 8,0	
46 – 49	60 x 8,0			
$42,4 < D \leq 44,5$	4,0 – 14,2	50	60 x 8,0	EI 90 / E 240 – C/U EI 90 / E 240 – C/C
		9	60 x 2,0	
		10 – 11	60 x 4,0	EI 120 / E 240 – C/U EI 120 / E 240 – C/C
		12 – 20	60 x 4,0	
		21 – 22	60 x 4,0	
		23	60 x 4,0	
		24 – 28	60 x 6,0	
		29 – 34	60 x 6,0	
		35 – 39	60 x 8,0	
40 – 45	60 x 8,0			
46 – 49	60 x 8,0			
$44,5 < D \leq 54,0$	2,2 – 3,9	50	60 x 8,0	EI 90 / E 240 – C/U EI 90 / E 240 – C/C
		9	60 x 2,0	
		10 – 11	60 x 4,0	
		12 – 20	60 x 4,0	EI 120 / E 240 – C/U EI 120 / E 240 – C/C
		21 – 22	60 x 4,0	
		23	60 x 4,0	EI 90 / E 120 – C/U EI 90 / E 120 – C/C
		24 – 28	60 x 6,0	
		29 – 34	60 x 6,0	
		35 – 39	60 x 8,0	
40 – 45	60 x 8,0			
46 – 49	60 x 8,0			
50	60 x 8,0			

Classifications given above for specific intumescent material dimensions are also valid for pipes with smaller pipe diameter and the same pipe wall thickness range.

INTU FR COLLAR L	Annex D2 of European Technical Assessment ETA-19/0844
Penetration seals made with use of INTU FR COLLAR L Metal pipes with insulation penetration seals in rigid wall	

Table D2, cont. Fire resistance class of steel pipes with continuous flexible elastomeric foam (FEF) insulation penetration seal in rigid wall thickness of: $t \geq 150$ mm, made with use of INTU FR COLLAR L in accordance with fig. F3 in Annex F:

Pipe diameter [mm]	Pipe wall thickness [mm]	Insulation thickness [mm]	Intumescent material width x thickness [mm]	Fire resistance class	
44,5 < D ≤ 54,0	4,0 – 14,2	9	60 x 2,0	EI 90 / E 240 – C/U EI 90 / E 240 – C/C	
		10 – 11	60 x 4,0		
		12 – 20	60 x 4,0		
		21 – 22	60 x 4,0		
		23	60 x 4,0	EI 120 / E 240 – C/U EI 120 / E 240 – C/C	
		24 – 28	60 x 6,0		
		29 – 34	60 x 6,0		
		35 – 39	60 x 8,0		
		40 – 45	60 x 8,0		
		46 – 49	60 x 8,0		
50	60 x 8,0				
54,0 < D ≤ 57,0	2,2 – 3,9	9	60 x 2,0	EI 90 / E 240 – C/U EI 90 / E 240 – C/C	
		10 – 11	60 x 4,0		
		12 – 20	60 x 4,0		
		21 – 22	60 x 4,0		
54,0 < D ≤ 57,0	2,2 – 3,9	23	60 x 4,0	EI 120 / E 240 – C/U EI 120 / E 240 – C/C	
		24 – 28	60 x 6,0	EI 90 / E 120 – C/U EI 90 / E 120 – C/C	
		29 – 34	60 x 6,0		
		35 – 39	60 x 8,0		
		40 – 45	60 x 8,0		
		46 – 49	60 x 8,0		
	50	60 x 8,0			
	4,0 -14,2	4,0 -14,2	9	60 x 2,0	EI 90 / E 240 – C/U EI 90 / E 240 – C/C
			10 – 11	60 x 4,0	
			12 – 20	60 x 4,0	
			21 – 22	60 x 4,0	
			23	60 x 4,0	EI 120 / E 240 – C/U EI 120 / E 240 – C/C
			24 – 28	60 x 6,0	
			29 – 34	60 x 6,0	
			35 – 39	60 x 8,0	
			40 – 45	60 x 8,0	
			46 – 49	60 x 8,0	
			46 – 49	60 x 8,0	
50			60 x 8,0		

Classifications given above for specific intumescent material dimensions are also valid for pipes with smaller pipe diameter and the same pipe wall thickness range.

INTU FR COLLAR L	Annex D3 of European Technical Assessment ETA-19/0844
Penetration seals made with use of INTU FR COLLAR L Metal pipes with insulation penetration seals in rigid wall	

Table D2, cont. Fire resistance class of steel pipes with continuous flexible elastomeric foam (FEF) insulation penetration seal in rigid wall thickness of: $t \geq 150$ mm, made with use of INTU FR COLLAR L in accordance with fig. F3 in Annex F:

Pipe diameter [mm]	Pipe wall thickness [mm]	Insulation thickness [mm]	Intumescent material width x thickness [mm]	Fire resistance class
57,0 < D ≤ 63,5	2,3 – 3,9	9	60 x 2,0	EI 90 / E 240 – C/U EI 90 / E 240 – C/C
		10 – 11	60 x 4,0	
		12 – 20	60 x 4,0	
		21 – 22	60 x 4,0	
		23	60 x 4,0	EI 120 / E 240 – C/U EI 120 / E 240 – C/C
		24 – 28	60 x 6,0	EI 90 / E 120 – C/U EI 90 / E 120 – C/C
		29 – 34	60 x 6,0	
		35 – 39	60 x 8,0	
		40 – 45	60 x 8,0	
	46 – 49	60 x 8,0		
	50	60 x 8,0		
	4,0 – 14,2	9	60 x 2,0	EI 120 / E 240 – C/U EI 120 / E 240 – C/C
		10 – 11	60 x 4,0	
		12 – 20	60 x 4,0	
		21 – 22	60 x 4,0	
		23	60 x 4,0	EI 90 / E 240 – C/U EI 90 / E 240 – C/C
		24 – 28	60 x 6,0	
		29 – 34	60 x 6,0	
35 – 39		60 x 8,0		
40 – 45		60 x 8,0		
46 – 49	60 x 8,0			
50	60 x 8,0			
63,5 < D ≤ 70,0	2,3 – 3,9	9	60 x 2,0	EI 90 / E 240 – C/U EI 90 / E 240 – C/C
		10 – 11	60 x 4,0	
		12 – 20	60 x 4,0	
		21 – 22	60 x 4,0	
		23	60 x 4,0	EI 120 / E 240 – C/U EI 120 / E 240 – C/C
		24 – 28	60 x 6,0	EI 90 / E 120 – C/U EI 90 / E 120 – C/C
		29 – 34	60 x 6,0	
		35 – 39	60 x 8,0	
		40 – 45	60 x 8,0	
	46 – 49	60 x 8,0		
	50	60 x 8,0		
	4,0 – 14,2	9	60 x 2,0	EI 90 / E 240 – C/U EI 90 / E 240 – C/C
		10 – 11	60 x 4,0	
		12 – 20	60 x 4,0	
		21 – 22	60 x 4,0	
		23	60 x 4,0	EI 120 / E 240 – C/U EI 120 / E 240 – C/C
		24 – 28	60 x 6,0	
		29 – 34	60 x 6,0	
35 – 39		60 x 8,0		
40 – 45		60 x 8,0		
46 – 49	60 x 8,0			
50	60 x 8,0			

Classifications given above for specific intumescent material dimensions are also valid for pipes with smaller pipe diameter and the same pipe wall thickness range.

INTU FR COLLAR L

Penetration seals made with use of INTU FR COLLAR L
Metal pipes with insulation penetration seals in rigid wall

Annex D4
of European
Technical Assessment
ETA-19/0844

Table D2, cont. Fire resistance class of steel pipes with continuous flexible elastomeric foam (FEF) insulation penetration seal in rigid wall thickness of: $t \geq 150$ mm, made with use of INTU FR COLLAR L in accordance with fig. F3 in Annex F:

Pipe diameter [mm]	Pipe wall thickness [mm]	Insulation thickness [mm]	Intumescent material width x thickness [mm]	Fire resistance class
70,0 < D ≤ 76,1	2,5 – 3,9	9	60 x 2,0	EI 90 / E 240 – C/U EI 90 / E 240 – C/C
		10 – 11	60 x 4,0	
		12 – 20	60 x 4,0	
		21 – 22	60 x 4,0	
		23	60 x 4,0	EI 120 / E 240 – C/U EI 120 / E 240 – C/C
		24 – 28	60 x 6,0	EI 90 / E 120 – C/U EI 90 / E 120 – C/C
		29 – 34	60 x 6,0	
		35 – 39	60 x 8,0	
		40 – 45	60 x 8,0	
	46 – 49	60 x 8,0		
	50	60 x 8,0		
	4,0 – 14,2	9	60 x 2,0	EI 90 / E 240 – C/U EI 90 / E 240 – C/C
		10 – 11	60 x 4,0	
		12 – 20	60 x 4,0	
		21 – 22	60 x 4,0	
		23	60 x 4,0	EI 120 / E 240 – C/U EI 120 / E 240 – C/C
		24 – 28	60 x 6,0	
		29 – 34	60 x 6,0	
35 – 39		60 x 8,0		
40 – 45		60 x 8,0		
46 – 49		60 x 8,0		
50	60 x 8,0			
76,1 < D ≤ 82,5	2,6 – 3,9	9	60 x 2,0	EI 90 / E 240 – C/U EI 90 / E 240 – C/C
		10 – 11	60 x 4,0	
		12 – 20	60 x 4,0	
		21 – 22	60 x 4,0	
		23	60 x 4,0	EI 120 / E 240 – C/U EI 120 / E 240 – C/C
		24 – 28	60 x 6,0	EI 90 / E 120 – C/U EI 90 / E 120 – C/C
		29 – 34	60 x 6,0	
		35 – 39	60 x 8,0	
		40 – 45	60 x 8,0	
	46 – 49	60 x 8,0		
	50	60 x 8,0		
	4,0 – 14,2	9	60 x 2,0	EI 90 / E 240 – C/U EI 90 / E 240 – C/C
		10 – 11	60 x 4,0	
		12 – 20	60 x 4,0	
		21 – 22	60 x 4,0	
		23	60 x 4,0	EI 120 / E 240 – C/U EI 120 / E 240 – C/C
		24 – 28	60 x 6,0	
		29 – 34	60 x 6,0	
35 – 39		60 x 8,0		
40 – 45		60 x 8,0		
46 – 49		60 x 8,0		
50	60 x 8,0			

Classifications given above for specific intumescent material dimensions are also valid for pipes with smaller pipe diameter and the same pipe wall thickness range.

INTU FR COLLAR L	Annex D5 of European Technical Assessment ETA-19/0844
Penetration seals made with use of INTU FR COLLAR L Metal pipes with insulation penetration seals in rigid wall	

Table D2, cont. Fire resistance class of steel pipes with continuous flexible elastomeric foam (FEF) insulation penetration seal in rigid wall thickness of: $t \geq 150$ mm, made with use of INTU FR COLLAR L in accordance with fig. F3 in Annex F:

Pipe diameter [mm]	Pipe wall thickness [mm]	Insulation thickness [mm]	Intumescent material width x thickness [mm]	Fire resistance class
82,5 < D ≤ 88,9	2,6 – 3,9	9	60 x 2,0	EI 90 / E 240 – C/U EI 90 / E 240 – C/C
		10 – 11	60 x 4,0	
		12 – 20	60 x 4,0	
		21 – 22	60 x 4,0	
		23	60 x 4,0	EI 120 / E 240 – C/U EI 120 / E 240 – C/C
		24 – 28	60 x 6,0	EI 90 / E 120 – C/U EI 90 / E 120 – C/C
		29 – 34	60 x 6,0	
		35 – 39	60 x 8,0	
	40 – 45	60 x 8,0		
	46 – 49	60 x 8,0		
	50	60 x 8,0		
	4,0 – 14,2	9	60 x 2,0	EI 90 / E 240 – C/U EI 90 / E 240 – C/C
		10 – 11	60 x 4,0	
		12 – 20	60 x 4,0	
		21 – 22	60 x 4,0	
		23	60 x 4,0	EI 120 / E 240 – C/U EI 120 / E 240 – C/C
		24 – 28	60 x 6,0	
		29 – 34	60 x 6,0	
35 – 39		60 x 8,0		
40 – 45		60 x 8,0		
46 – 49		60 x 8,0		
50	60 x 8,0			
88,9 < D ≤ 101,6	2,9 – 14,2	9	60 x 2,0	EI 45 / E 120 – C/U EI 45 / E 120 – C/C
		10 – 11	60 x 4,0	EI 45 / E 60 – C/U EI 45 / E 60 – C/C
		12 – 20	60 x 4,0	
		21 – 22	60 x 4,0	
		23 – 28	60 x 6,0	
		29 – 34	60 x 6,0	
		35 – 39	60 x 8,0	
		40 – 45	60 x 8,0	
		46 – 49	60 x 8,0	
50	60 x 8,0			
101,6 < D ≤ 108	3,0 – 14,2	9	60 x 2,0	EI 45 / E 120 – C/U EI 45 / E 120 – C/C
		10 – 11	60 x 4,0	EI 45 / E 60 – C/U EI 45 / E 60 – C/C
		12 – 20	60 x 4,0	
		21 – 22	60 x 4,0	
		23 – 28	60 x 6,0	
		29 – 34	60 x 6,0	
		35 – 39	60 x 8,0	
		40 – 45	60 x 8,0	
		46 – 49	60 x 8,0	
50	60 x 8,0			

Classifications given above for specific intumescent material dimensions are also valid for pipes with smaller pipe diameter and the same pipe wall thickness range.

INTU FR COLLAR L

Penetration seals made with use of INTU FR COLLAR L
Metal pipes with insulation penetration seals in rigid wall

Annex D6
of European
Technical Assessment
ETA-19/0844

Table D2, cont. Fire resistance class of steel pipes with continuous flexible elastomeric foam (FEF) insulation penetration seal in rigid wall thickness of: $t \geq 150$ mm, made with use of INTU FR COLLAR L in accordance with fig. F3 in Annex F:

Pipe diameter [mm]	Pipe wall thickness [mm]	Insulation thickness [mm]	Intumescent material width x thickness [mm]	Fire resistance class
108 < D ≤ 114,3	3,2 – 14,2	9	60 x 2,0	EI 45 / E 120 – C/U EI 45 / E 120 – C/C
		10 – 11	60 x 4,0	EI 45 / E 60 – C/U EI 45 / E 60 – C/C
		12 – 20	60 x 4,0	
		21 – 22	60 x 4,0	
		23 – 28	60 x 6,0	
		29 – 34	60 x 6,0	
		35 – 39	60 x 8,0	
		40 – 45	60 x 8,0	
		46 – 49	60 x 8,0	
50	60 x 8,0			
114,3 < D ≤ 127	3,4 – 14,2	9	60 x 2,0	EI 45 / E 120 – C/U EI 45 / E 120 – C/C
		10 – 11	60 x 4,0	EI 45 / E 60 – C/U EI 45 / E 60 – C/C
		12 – 20	60 x 4,0	
		21 – 22	60 x 4,0	
		23 – 28	60 x 6,0	
		29 – 34	60 x 6,0	
		35 – 39	60 x 8,0	
		40 – 45	60 x 8,0	
		46 – 49	60 x 8,0	
50	60 x 8,0			
127 < D ≤ 133	3,5 – 14,2	9	60 x 2,0	EI 45 / E 120 – C/U EI 45 / E 120 – C/C
		10 – 11	60 x 4,0	EI 45 / E 60 – C/U EI 45 / E 60 – C/C
		12 – 20	60 x 4,0	
		21 – 22	60 x 4,0	
		23 – 28	60 x 6,0	
		29 – 34	60 x 6,0	
		35 – 39	60 x 8,0	
		40 – 45	60 x 8,0	
		46 – 49	60 x 8,0	
50	60 x 8,0			
133 < D ≤ 139,7	3,7 – 14,2	9	60 x 2,0	EI 45 / E 120 – C/U EI 45 / E 120 – C/C
		10 – 11	60 x 4,0	EI 45 / E 60 – C/U EI 45 / E 60 – C/C
		12 – 20	60 x 4,0	
		21 – 22	60 x 4,0	
		23 – 28	60 x 6,0	
		29 – 34	60 x 6,0	
		35 – 39	60 x 8,0	
		40 – 45	60 x 8,0	
		46 – 49	60 x 8,0	
50	60 x 8,0			

Classifications given above for specific intumescent material dimensions are also valid for pipes with smaller pipe diameter and the same pipe wall thickness range.

INTU FR COLLAR L	Annex D7 of European Technical Assessment ETA-19/0844
Penetration seals made with use of INTU FR COLLAR L Metal pipes with insulation penetration seals in rigid wall	

Table D2, cont. Fire resistance class of steel pipes with continuous flexible elastomeric foam (FEF) insulation penetration seal in rigid wall thickness of: $t \geq 150$ mm, made with use of INTU FR COLLAR L in accordance with fig. F3 in Annex F:

Pipe diameter [mm]	Pipe wall thickness [mm]	Insulation thickness [mm]	Intumescent material width x thickness [mm]	Fire resistance class
139,7 < D ≤ 152,4	3,9 – 14,2	9	60 x 2,0	EI 45 / E 120 – C/U EI 45 / E 120 – C/C
		10 – 11	60 x 4,0	EI 45 / E 60 – C/U EI 45 / E 60 – C/C
		12 – 20	60 x 4,0	
		21 – 22	60 x 4,0	
		23 – 28	60 x 6,0	
		29 – 34	60 x 6,0	
		35 – 39	60 x 8,0	
		40 – 45	60 x 8,0	
		46 – 49	60 x 8,0	
50	60 x 8,0			
152,4 < D ≤ 159	4,0 – 14,2	9	60 x 2,0	EI 45 / E 120 – C/U EI 45 / E 120 – C/C
		10 – 11	60 x 4,0	EI 45 / E 60 – C/U EI 45 / E 60 – C/C
		12 – 20	60 x 4,0	
		21 – 22	60 x 4,0	
		23 – 28	60 x 6,0	
		29 – 34	60 x 6,0	
		35 – 39	60 x 8,0	
		40 – 45	60 x 8,0	
		46 – 49	60 x 8,0	
50	60 x 8,0			

Classifications given above for specific intumescent material dimensions are also valid for pipes with smaller pipe diameter and the same pipe wall thickness range.

INTU FR COLLAR L

Penetration seals made with use of INTU FR COLLAR L
Metal pipes with insulation penetration seals in rigid wall

Annex D8
of European
Technical Assessment
ETA-19/0844

Table D3. Fire resistance class of copper pipes with continuous flexible elastomeric foam (FEF) insulation penetration seal in rigid floor thickness of: $t \geq 150$ mm, made with use of INTU FR COLLAR L in accordance with fig. F6 in Annex F:

Pipe diameter [mm]	Pipe wall thickness [mm]	Insulation thickness [mm]	Intumescent material width x thickness [mm]	Fire resistance class
$D \leq 15,0$	$\geq 1,0$	9	60 x 2,0	EI 120 – C/U EI 120 – C/C
		10 – 19	60 x 4,0	EI 90 – C/U EI 90 – C/C
		20 – 22	60 x 4,0	
		23 – 36	60 x 6,0	
		37 – 49	60 x 8,0	
		50	60 x 8,0	
$15,0 < D \leq 42,4$	1,4 – 14,2	9	60 x 2,0	EI 120 – C/U EI 120 – C/C
		10 – 19	60 x 4,0	EI 90 – C/U EI 90 – C/C
		20 – 22	60 x 4,0	
		23 – 36	60 x 6,0	
		37 – 50	60 x 8,0	
		50	60 x 8,0	
$42,4 < D \leq 44,5$	1,4 – 14,2	9	60 x 2,0	EI 120 – C/U EI 120 – C/C
		10 – 19	60 x 4,0	EI 90 – C/U EI 90 – C/C
		20 – 22	60 x 4,0	
		23 – 36	60 x 6,0	
		37 – 50	60 x 8,0	
		50	60 x 8,0	
$44,5 < D \leq 54,0$	1,5 – 14,2	9	60 x 2,0	EI 120 – C/U EI 120 – C/C
		10 – 19	60 x 4,0	EI 90 – C/U EI 90 – C/C
		20 – 22	60 x 4,0	
		23 – 36	60 x 6,0	
		37 – 50	60 x 8,0	
		50	60 x 8,0	

Classifications given above for specific intumescent material dimensions are also valid for pipes with smaller pipe diameter and the same pipe wall thickness range.

INTU FR COLLAR L	Annex D9 of European Technical Assessment ETA-19/0844
Penetration seals made with use of INTU FR COLLAR L Metal pipes with insulation penetration seals in rigid floor	

Table D4. Fire resistance class of steel pipes with continuous flexible elastomeric foam (FEF) insulation penetration seal in rigid floor thickness of: $t \geq 150$ mm, made with use of INTU FR COLLAR L in accordance with fig. F6 in Annex F:

Pipe diameter [mm]	Pipe wall thickness [mm]	Insulation thickness [mm]	Intumescent material width x thickness [mm]	Fire resistance class
$D \leq 42,4$	2,0 – 14,2	9	60 x 2,0	EI 240 – C/U EI 240 – C/C
		10 – 11	60 x 4,0	EI 120 – C/U EI 120 – C/C
		12 – 20	60 x 4,0	
		21 – 22	60 x 4,0	
		23 – 28	60 x 6,0	
		29 – 34	60 x 6,0	
		35 – 39	60 x 8,0	
		40 – 45	60 x 8,0	
		46 – 49	60 x 8,0	
50	60 x 8,0			
$42,4 < D \leq 44,5$	2,1 – 14,2	9	60 x 2,0	EI 120 / E 240 – C/U EI 120 / E 240 – C/C
		10 – 11	60 x 4,0	EI 120 – C/U EI 120 – C/C
		12 – 20	60 x 4,0	
		21 – 22	60 x 4,0	
		23 – 28	60 x 6,0	
		29 – 34	60 x 6,0	
		35 – 39	60 x 8,0	
		40 – 45	60 x 8,0	
		46 – 49	60 x 8,0	
50	60 x 8,0			
$44,5 < D \leq 54,0$	2,2 – 14,2	9	60 x 2,0	EI 120 / E 240 – C/U EI 120 / E 240 – C/C
		10 – 11	60 x 4,0	EI 120 – C/U EI 120 – C/C
		12 – 20	60 x 4,0	
		21 – 22	60 x 4,0	
		23 – 28	60 x 6,0	
		29 – 34	60 x 6,0	
		35 – 39	60 x 8,0	
		40 – 45	60 x 8,0	
		46 – 49	60 x 8,0	
50	60 x 8,0			
$54,0 < D \leq 57,0$	2,2 – 14,2	9	60 x 2,0	EI 120 / E 240 – C/U EI 120 / E 240 – C/C
		10 – 11	60 x 4,0	EI 120 – C/U EI 120 – C/C
		12 – 20	60 x 4,0	
		21 – 22	60 x 4,0	
		23 – 28	60 x 6,0	
		29 – 34	60 x 6,0	
		35 – 39	60 x 8,0	
		40 – 45	60 x 8,0	
		46 – 49	60 x 8,0	
50	60 x 8,0			

Classification given above for specific intumescent material dimensions is also valid for pipes with smaller pipe diameter and the same pipe wall thickness range.

INTU FR COLLAR L

Penetration seals made with use of INTU FR COLLAR L
Metal pipes with insulation penetration seals in rigid floor

Annex D10
of European
Technical Assessment
ETA-19/0844

Table D4, cont. Fire resistance class of steel pipes with continuous flexible elastomeric foam (FEF) insulation penetration seal in rigid floor thickness of: $t \geq 150$ mm, made with use of INTU FR COLLAR L in accordance with fig. F6 in Annex F:

Pipe diameter [mm]	Pipe wall thickness [mm]	Insulation thickness [mm]	Intumescent material width x thickness [mm]	Fire resistance class
57,0 < D ≤ 63,5	2,3 – 14,2	9	60 x 2,0	EI 120 / E 240 – C/U EI 120 / E 240 – C/C
		10 – 11	60 x 4,0	EI 120 – C/U EI 120 – C/C
		12 – 20	60 x 4,0	
		21 – 22	60 x 4,0	
		23 – 28	60 x 6,0	
		29 – 34	60 x 6,0	
		35 – 39	60 x 8,0	
		40 – 45	60 x 8,0	
		46 – 49	60 x 8,0	
50	60 x 8,0			
63,5 < D ≤ 70,0	2,3 – 14,2	9	60 x 2,0	EI 120 / E 240 – C/U EI 120 / E 240 – C/C
		10 – 11	60 x 4,0	EI 120 – C/U EI 120 – C/C
		12 – 20	60 x 4,0	
		21 – 22	60 x 4,0	
		23 – 28	60 x 6,0	
		29 – 34	60 x 6,0	
		35 – 39	60 x 8,0	
		40 – 45	60 x 8,0	
		46 – 49	60 x 8,0	
50	60 x 8,0			
70,0 < D ≤ 76,1	2,5 – 14,2	9	60 x 2,0	EI 120 / E 240 – C/U EI 120 / E 240 – C/C
		10 – 11	60 x 4,0	EI 120 – C/U EI 120 – C/C
		12 – 20	60 x 4,0	
		21 – 22	60 x 4,0	
		23 – 28	60 x 6,0	
		29 – 34	60 x 6,0	
		35 – 39	60 x 8,0	
		40 – 45	60 x 8,0	
		46 – 49	60 x 8,0	
50	60 x 8,0			

Classification given above for specific intumescent material dimensions is also valid for pipes with smaller pipe diameter and the same pipe wall thickness range.

INTU FR COLLAR L	Annex D11 of European Technical Assessment ETA-19/0844
Penetration seals made with use of INTU FR COLLAR L Metal pipes with insulation penetration seals in rigid floor	

Table D4, cont. Fire resistance class of steel pipes with continuous flexible elastomeric foam (FEF) insulation penetration seal in rigid floor thickness of: $t \geq 150$ mm, made with use of INTU FR COLLAR L in accordance with fig. F6 in Annex F:

Pipe diameter [mm]	Pipe wall thickness [mm]	Insulation thickness [mm]	Intumescent material width x thickness [mm]	Fire resistance class
76,1 < D ≤ 82,5	2,6 – 14,2	9	60 x 2,0	EI 120 / E 240 – C/U EI 120 / E 240 – C/C
		10 – 11	60 x 4,0	EI 120 – C/U EI 120 – C/C
		12 – 20	60 x 4,0	
		21 – 22	60 x 4,0	
		23 – 28	60 x 6,0	
		29 – 34	60 x 6,0	
		35 – 39	60 x 8,0	
		40 – 45	60 x 8,0	
		46 – 49	60 x 8,0	
50	60 x 8,0			
82,5 < D ≤ 88,9	2,6 – 14,2	9	60 x 2,0	EI 120 / E 240 – C/U EI 120 / E 240 – C/C
		10 – 11	60 x 4,0	EI 120 – C/U EI 120 – C/C
		12 – 20	60 x 4,0	
		21 – 22	60 x 4,0	
		23 – 28	60 x 6,0	
		29 – 34	60 x 6,0	
		35 – 39	60 x 8,0	
		40 – 45	60 x 8,0	
		46 – 49	60 x 8,0	
50	60 x 8,0			
88,9 < D ≤ 101,6	2,9 – 14,2	9	60 x 2,0	EI 120 – C/U EI 120 – C/C
		10 – 11	60 x 4,0	
		12 – 20	60 x 4,0	
		21 – 22	60 x 4,0	
		23 – 28	60 x 6,0	
		29 – 34	60 x 6,0	
		35 – 39	60 x 8,0	
		40 – 45	60 x 8,0	
		46 – 49	60 x 8,0	
50	60 x 8,0	EI 180 / E 240 – C/U EI 180 / E 240 – C/C		

Classifications given above for specific intumescent material dimensions are also valid for pipes with smaller pipe diameter and the same pipe wall thickness range.

INTU FR COLLAR L

Penetration seals made with use of INTU FR COLLAR L
Metal pipes with insulation penetration seals in rigid floor

Annex D12
of European
Technical Assessment
ETA-19/0844

Table D4, cont. Fire resistance class of steel pipes with continuous flexible elastomeric foam (FEF) insulation penetration seal in rigid floor thickness of: $t \geq 150$ mm, made with use of INTU FR COLLAR L in accordance with fig. F6 in Annex F:

Pipe diameter [mm]	Pipe wall thickness [mm]	Insulation thickness [mm]	Intumescent material width x thickness [mm]	Fire resistance class
101,6 < D ≤ 108	3,0 – 14,2	9	60 x 2,0	EI 120 – C/U EI 120 – C/C
		10 – 11	60 x 4,0	
		12 – 20	60 x 4,0	
		21 – 22	60 x 4,0	
		23 – 28	60 x 6,0	
		29 – 34	60 x 6,0	
		35 – 39	60 x 8,0	
		40 – 45	60 x 8,0	
		46 – 49	60 x 8,0	
	50	60 x 8,0	EI 180 / E 240 – C/U EI 180 / E 240 – C/C	
108 < D ≤ 114,3	3,2 – 14,2	9	60 x 2,0	EI 120 – C/U EI 120 – C/C
		10 – 11	60 x 4,0	
		12 – 20	60 x 4,0	
		21 – 22	60 x 4,0	
		23 – 28	60 x 6,0	
		29 – 34	60 x 6,0	
		35 – 39	60 x 8,0	
		40 – 45	60 x 8,0	
		46 – 49	60 x 8,0	
	50	60 x 8,0	EI 180 / E 240 – C/U EI 180 / E 240 – C/C	
114,3 < D ≤ 127	3,4 – 14,2	9	60 x 2,0	EI 120 – C/U EI 120 – C/C
		10 – 11	60 x 4,0	
		12 – 20	60 x 4,0	
		21 – 22	60 x 4,0	
		23 – 28	60 x 6,0	
		29 – 34	60 x 6,0	
		35 – 39	60 x 8,0	
		40 – 45	60 x 8,0	
		46 – 49	60 x 8,0	
	50	60 x 8,0	EI 180 / E 240 – C/U EI 180 / E 240 – C/C	
127 < D ≤ 133	3,5 – 14,2	9	60 x 2,0	EI 120 – C/U EI 120 – C/C
		10 – 11	60 x 4,0	
		12 – 20	60 x 4,0	
		21 – 22	60 x 4,0	
		23 – 28	60 x 6,0	
		29 – 34	60 x 6,0	
		35 – 39	60 x 8,0	
		40 – 45	60 x 8,0	
		46 – 49	60 x 8,0	
	50	60 x 8,0	EI 180 / E 240 – C/U EI 180 / E 240 – C/C	

Classifications given above for specific intumescent material dimensions are also valid for pipes with smaller pipe diameter and the same pipe wall thickness range.

INTU FR COLLAR L	Annex D13 of European Technical Assessment ETA-19/0844
Penetration seals made with use of INTU FR COLLAR L Metal pipes with insulation penetration seals in rigid floor	

Table D4, cont. Fire resistance class of steel pipes with continuous flexible elastomeric foam (FEF) insulation penetration seal in rigid floor thickness of: $t \geq 150$ mm, made with use of INTU FR COLLAR L in accordance with fig. F6 in Annex F:

Pipe diameter [mm]	Pipe wall thickness [mm]	Insulation thickness [mm]	Intumescent material width x thickness [mm]	Fire resistance class
133 < D ≤ 139,7	3,7 – 14,2	9	60 x 2,0	EI 120 – C/U EI 120 – C/C
		10 – 11	60 x 4,0	
		12 – 20	60 x 4,0	
		21 – 22	60 x 4,0	
		23 – 28	60 x 6,0	
		29 – 34	60 x 6,0	
		35 – 39	60 x 8,0	
		40 – 45	60 x 8,0	
		46 – 49	60 x 8,0	
		50	60 x 8,0	EI 180 / E 240 – C/U EI 180 / E 240 – C/C
139,7 < D ≤ 152,4	3,9 – 14,2	9	60 x 2,0	EI 120 – C/U EI 120 – C/C
		10 – 11	60 x 4,0	
		12 – 20	60 x 4,0	
		21 – 22	60 x 4,0	
		23 – 28	60 x 6,0	
		29 – 34	60 x 6,0	
		35 – 39	60 x 8,0	
		40 – 45	60 x 8,0	
		46 – 49	60 x 8,0	
		50	60 x 8,0	EI 180 / E 240 – C/U EI 180 / E 240 – C/C
152,4 < D ≤ 159	4,0 – 14,2	9	60 x 2,0	EI 120 – C/U EI 120 – C/C
		10 – 11	60 x 4,0	
		12 – 20	60 x 4,0	
		21 – 22	60 x 4,0	
		23 – 28	60 x 6,0	
		29 – 34	60 x 6,0	
		35 – 39	60 x 8,0	
		40 – 45	60 x 8,0	
		46 – 49	60 x 8,0	
		50	60 x 8,0	EI 180 / E 240 – C/U EI 180 / E 240 – C/C
159 < D ≤ 219	4,5 – 14,2	50	60 x 8,0	EI 45 – C/U EI 45 – C/C

Classifications given above for specific intumescent material dimensions are also valid for pipes with smaller pipe diameter and the same pipe wall thickness range.

INTU FR COLLAR L

Penetration seals made with use of INTU FR COLLAR L
Metal pipes with insulation penetration seals in rigid floor

Annex D14
of European
Technical Assessment
ETA-19/0844

Table E1. Fire resistance class of PVC-U / PVC-C pipes penetration seal in rigid wall thickness of: $t \geq 150$ mm, made with use of INTU FR SLEEVE in accordance with fig. F4 in Annex F:

Pipe diameter [mm]	Pipe wall thickness [mm]	Insulation thickness [mm]	Intumescent material width x thickness [mm]	Fire resistance class
D ≤ 32	2,7	–	60 x 6,0	EI 120 / E 180 – U/C EI 120 / E 180 – C/C
	2,8 – 3,2	–	60 x 12,0	EI 120 – U/C EI 120 – C/C
	3,3 – 3,9	–	60 x 12,0	EI 60 – U/C EI 60 – C/C
32 < D ≤ 40	2,7	–	60 x 6,0	EI 120 / E 180 – U/C EI 120 / E 180 – C/C
	2,8 – 3,2	–	60 x 12,0	EI 120 – U/C EI 120 – C/C
	3,3 – 3,9	–	60 x 12,0	EI 60 – U/C EI 60 – C/C
40 < D ≤ 50	2,7	–	60 x 6,0	EI 120 / E 180 – U/C EI 120 / E 180 – C/C
	2,8 – 3,2	–	60 x 12,0	EI 120 – U/C EI 120 – C/C
	3,3 – 3,9	–	60 x 12,0	EI 60 – U/C EI 60 – C/C
50 < D ≤ 55	2,7	–	60 x 6,0	EI 120 / E 180 – U/C EI 120 / E 180 – C/C
	2,8 – 3,2	–	60 x 12,0	EI 120 – U/C EI 120 – C/C
	3,3 – 3,9	–	60 x 12,0	EI 60 – U/C EI 60 – C/C
55 < D ≤ 63	2,7	–	60 x 6,0	EI 120 / E 180 – U/C EI 120 / E 180 – C/C
	2,8 – 3,2	–	60 x 12,0	EI 120 – U/C EI 120 – C/C
	3,3 – 3,9	–	60 x 12,0	EI 60 – U/C EI 60 – C/C
63 < D ≤ 75	2,7	–	60 x 6,0	EI 120 / E 180 – U/C EI 120 / E 180 – C/C
	2,8 – 3,2	–	60 x 12,0	EI 120 – U/C EI 120 – C/C
	3,3 – 3,9	–	60 x 12,0	EI 60 – U/C EI 60 – C/C
75 < D ≤ 90	2,7	–	60 x 6,0	EI 120 / E 180 – U/C EI 120 / E 180 – C/C
	2,8 – 3,2	–	60 x 12,0	EI 120 – U/C EI 120 – C/C
	3,3 – 3,9	–	60 x 12,0	EI 60 – U/C EI 60 – C/C

Classifications given above for specific intumescent material dimensions are also valid for pipes with smaller pipe diameter and the same pipe wall thickness range.

INTU FR SLEEVE	Annex E1 of European Technical Assessment ETA-19/0844
Penetration seals made with use of INTU FR SLEEVE Plastic pipes without insulation penetration seals in rigid wall	

Table E1, cont. Fire resistance class of PVC-U / PVC-C pipes penetration seal in rigid wall thickness of: $t \geq 150$ mm, made with use of INTU FR SLEEVE in accordance with fig. F4 in Annex F:

Pipe diameter [mm]	Pipe wall thickness [mm]	Insulation thickness [mm]	Intumescent material width x thickness [mm]	Fire resistance class
$90 < D \leq 110$	2,7	–	60 x 6,0	EI 120 / E 180 – U/C EI 120 / E 180 – C/C
	2,8 – 3,2	–	60 x 10,0	EI 120 – U/C EI 120 – C/C
	3,3 – 3,9	–	60 x 12,0	EI 60 – U/C EI 60 – C/C
$110 < D \leq 125$	3,2	–	60 x 10,0	EI 120 – U/C EI 120 – C/C
	3,3 – 3,9	–	60 x 12,0	EI 60 – U/C EI 60 – C/C
$125 < D \leq 160$	3,2	–	60 x 12,0	EI 120 – U/C EI 120 – C/C
	3,3 – 3,9	–	60 x 12,0	EI 60 – U/C EI 60 – C/C

Classifications given above for specific intumescent material dimensions are also valid for pipes with smaller pipe diameter and the same pipe wall thickness range.

INTU FR SLEEVE

Penetration seals made with use of INTU FR SLEEVE
Plastic pipes without insulation penetration seals in rigid wall

Annex E2
of European
Technical Assessment
ETA-19/0844

Table E2. Fire resistance class of PVC-U / PVC-C pipes penetration seal in rigid floor thickness of: $t \geq 150$ mm, made with use of INTU FR SLEEVE in accordance with fig. F7 in Annex F:

Pipe diameter [mm]	Pipe wall thickness [mm]	Insulation thickness [mm]	Intumescent material width x thickness [mm]	Fire resistance class
D ≤ 32	2,2	–	60 x 6,0	EI 180 / E 240 – U/C EI 180 / E 240 – C/C
	2,3 – 3,2	–	60 x 12,0	EI 120 – U/C EI 120 – C/C
32 < D ≤ 40	2,2	–	60 x 6,0	EI 180 / E 240 – U/C EI 180 / E 240 – C/C
	2,3 – 3,2	–	60 x 12,0	EI 120 – U/C EI 120 – C/C
40 < D ≤ 50	2,2	–	60 x 6,0	EI 180 / E 240 – U/C EI 180 / E 240 – C/C
	2,3 – 3,2	–	60 x 12,0	EI 120 – U/C EI 120 – C/C
50 < D ≤ 55	2,2	–	60 x 6,0	EI 180 / E 240 – U/C EI 180 / E 240 – C/C
	2,3 – 3,2	–	60 x 12,0	EI 120 – U/C EI 120 – C/C
55 < D ≤ 63	2,2	–	60 x 6,0	EI 180 / E 240 – U/C EI 180 / E 240 – C/C
	2,3 – 3,2	–	60 x 12,0	EI 120 – U/C EI 120 – C/C
63 < D ≤ 75	2,2	–	60 x 6,0	EI 180 / E 240 – U/C EI 180 / E 240 – C/C
	2,3 – 3,2	–	60 x 12,0	EI 120 – U/C EI 120 – C/C
75 < D ≤ 90	2,2	–	60 x 6,0	EI 180 / E 240 – U/C EI 180 / E 240 – C/C
	2,3 – 3,2	–	60 x 12,0	EI 120 – U/C EI 120 – C/C
90 < D ≤ 110	2,2	–	60 x 6,0	EI 180 / E 240 – U/C EI 180 / E 240 – C/C
	2,3 – 3,2	–	60 x 10,0	EI 120 – U/C EI 120 – C/C
110 < D ≤ 125	3,2	60 x 10,0		
125 < D ≤ 160	3,2	60 x 12,0		

INTU FR SLEEVE
Penetration seals made with use of INTU FR SLEEVE
 Plastic pipes without insulation penetration seals in rigid floor

Annex E3
 of European
 Technical Assessment
 ETA-19/0844

Fig. F1. Plastic pipe without insulation penetration seals made with use of INTU FR COLLAR in flexible wall

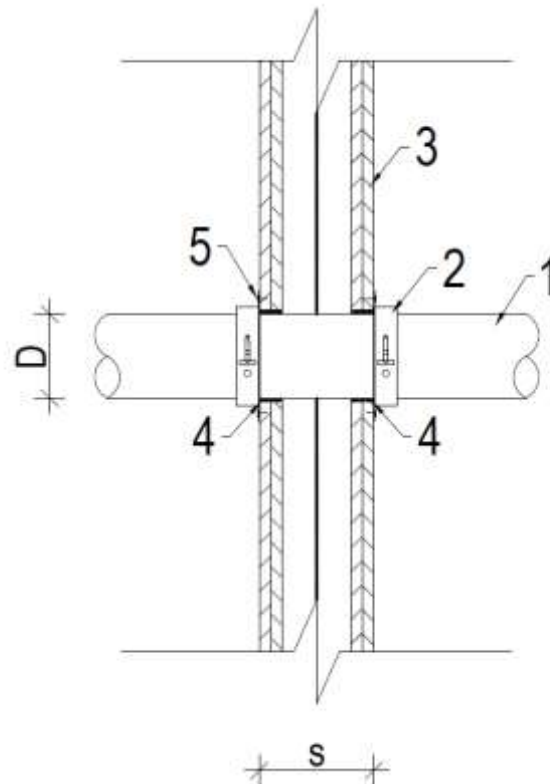

- 1 Plastic pipe with diameter of D and pipe wall thickness t
- 2 INTU FR COLLAR; layers of intumescent material in accordance with fire classification
- 3 Flexible wall supporting construction with thickness in accordance with fire classification
- 4 Space between the pipe and wall filled with INTU FR MASTIC; ring with max. 25 mm width, on the depth of at least 10 mm, on both sides of the wall
- 5 Collar fixing – steel fastener with dimensions min. $\varnothing 6 \times 40$ mm

INTU FR COLLAR

Construction details

Plastic pipe without insulation penetration seals in flexible wall

Annex F1
of European
Technical Assessment
ETA-19/0844

Fig. F2. Plastic pipe without insulation penetration seals made with use of INTU FR COLLAR in rigid wall

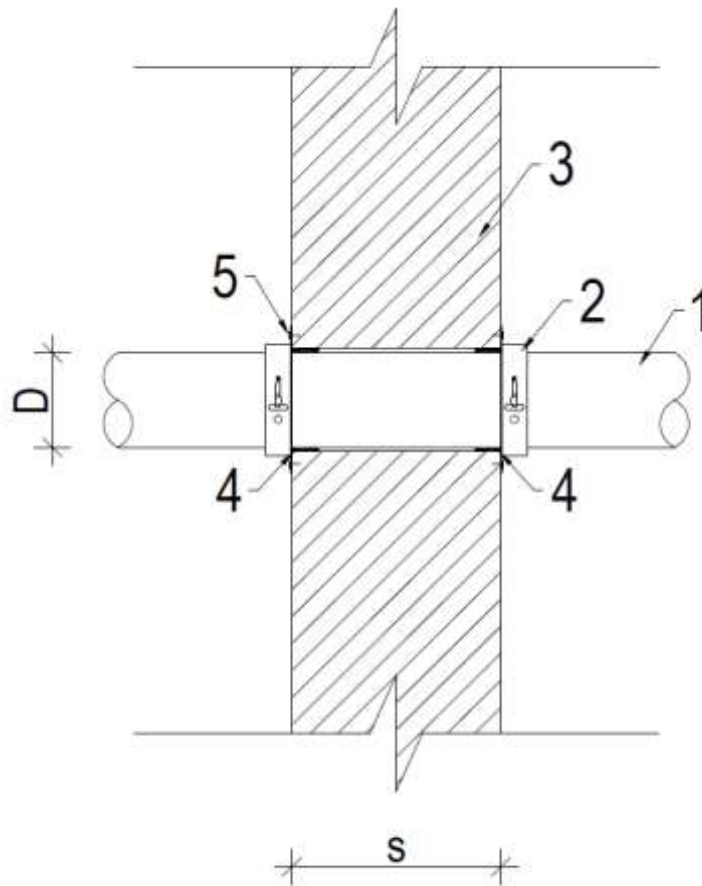

- 1 Plastic pipe with diameter of D and pipe wall thickness t
- 2 INTU FR COLLAR; layers of intumescent material in accordance with fire classification
- 3 Rigid wall supporting construction with thickness in accordance with fire classification
- 4 Space between the pipe and wall filled with INTU FR MASTIC; ring with max. 25 mm width, on the depth of at least 10 mm, on both sides of the wall
- 5 Collar fixing – steel fastener with dimensions min. $\varnothing 6 \times 40$ mm

INTU FR COLLAR

Construction details

Plastic pipe without insulation penetration seals in rigid wall

Annex F2
of European
Technical Assessment
ETA-19/0844

Fig. F3. Metal pipe with flexible elastomeric foam (FEF) insulation penetration seals made with use of INTU FR COLLAR L in rigid wall

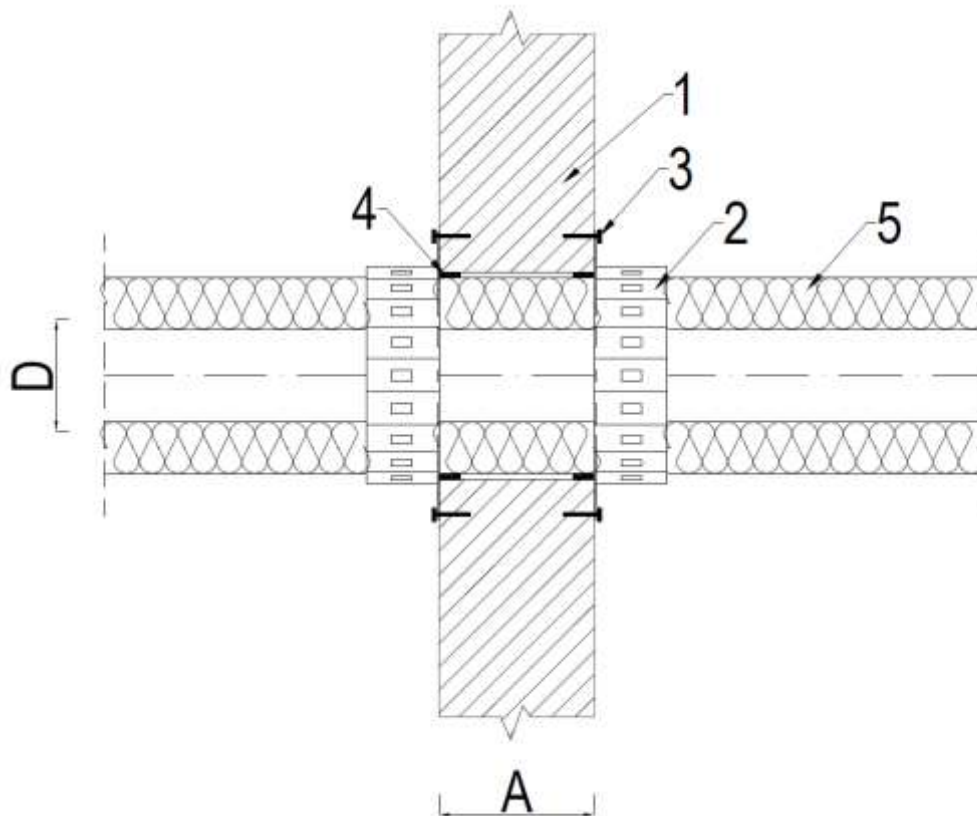

- 1 Rigid wall supporting construction with thickness in accordance with fire classification
- 2 INTU FR COLLAR L; layers of intumescent material in accordance with fire classification
- 3 Collar fixing – steel fastener with dimensions min. $\varnothing 6 \times 40$ mm
- 4 Space between the pipe and wall filled with INTU FR MASTIC; ring with max. 25 mm width, on the depth of at least 10 mm, on both sides of the wall
- 5 Metal pipe (with FEF insulation) with diameter of D and pipe wall thickness t

INTU FR COLLAR L

Construction details

Metal pipe with insulation penetration seals in rigid wall

Annex F3
of European
Technical Assessment
ETA-19/0844

Fig. F4. Plastic pipe without insulation penetration seals made with use of INTU FR SLEEVE in rigid wall

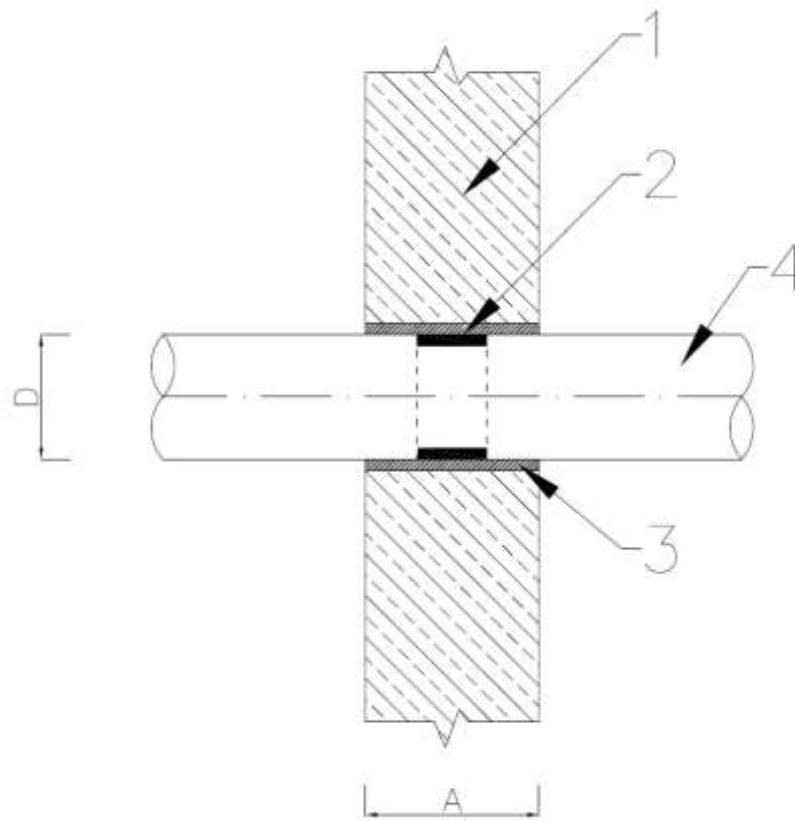

- 1 Rigid wall supporting construction with thickness in accordance with fire classification
- 2 INTU FR SLEEVE; layers of intumescent material in accordance with fire classification
- 3 Space between the pipe and wall filled with cement mortar; ring with max. 25 mm width, on the whole depth of the wall
- 4 Plastic pipe with diameter of D and pipe wall thickness t

INTU FR SLEVE	Annex D4 of European Technical Assessment ETA-19/0844
Construction details Plastic pipe without insulation penetration seals in rigid wall	

Fig. F5. Plastic pipe without insulation penetration seals made with use of INTU FR COLLAR in rigid floor

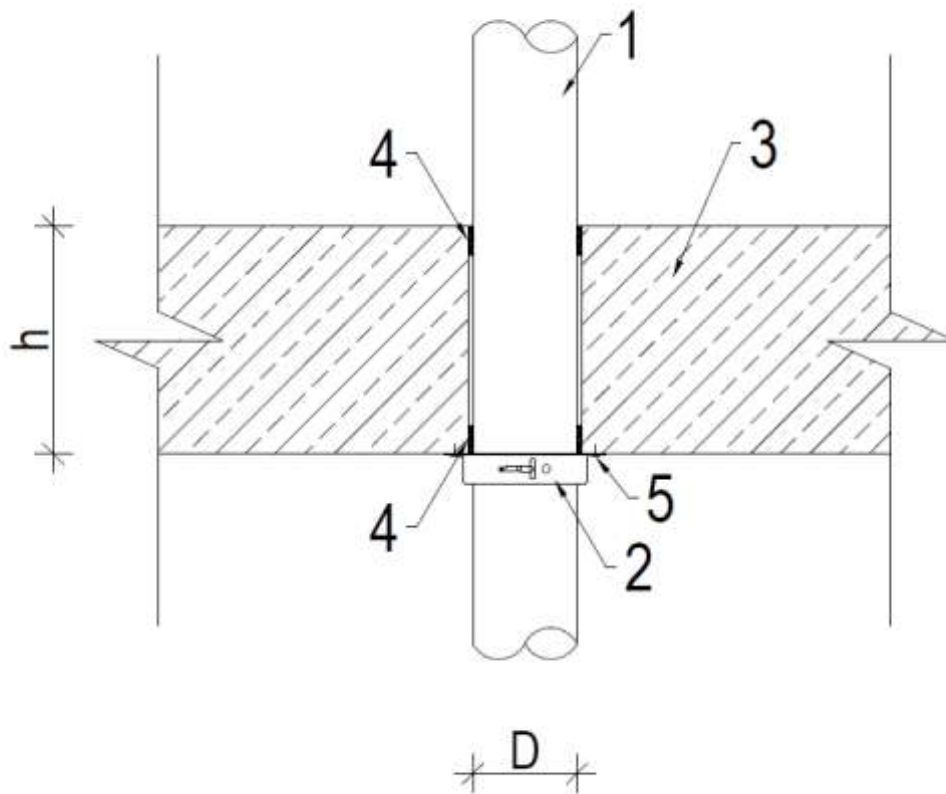

- 1 Plastic pipe with diameter of D and pipe wall thickness t
- 2 INTU FR COLLAR; layers of intumescent material in accordance with fire classification
- 3 Rigid floor supporting construction with thickness in accordance with fire classification
- 4 Space between the pipe and floor filled with INTU FR MASTIC; ring with max. 25 mm width, on the depth of at least 10 mm, on both sides of the floor
- 5 Collar fixing – steel fastener with dimensions min. $\varnothing 6 \times 40$ mm

INTU FR COLLAR

Construction details

Plastic pipe without insulation penetration seals in rigid floor

Annex F5
of European
Technical Assessment
ETA-19/0844

Fig. F6. Metal pipe with insulation penetration seal made with use of INTU FR COLLAR L in rigid floor

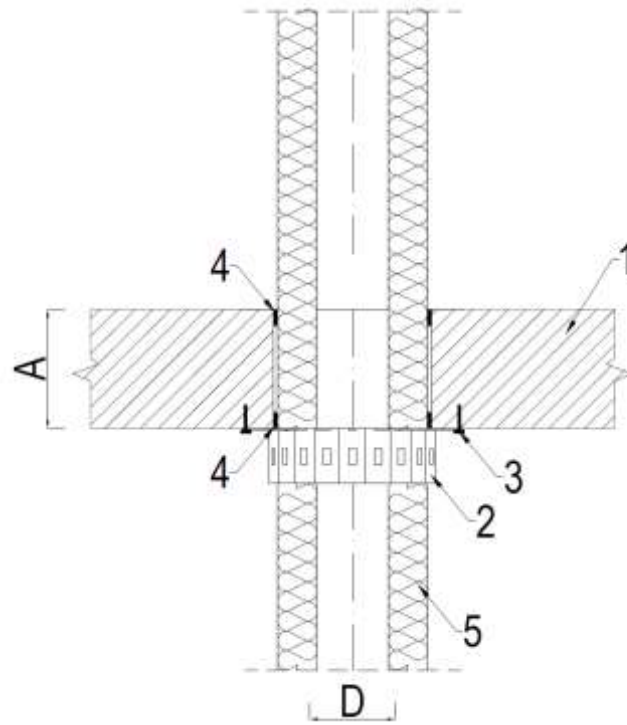

- 1 Rigid floor supporting construction with thickness in accordance with fire classification
- 2 INTU FR COLLAR L; layers of intumescent material in accordance with fire classification
- 3 Collar fixing – steel fastener with dimensions min. $\varnothing 6 \times 40$ mm
- 4 Space between the pipe and floor filled with INTU FR MASTIC; ring with max. 25 mm width, on the depth of at least 10 mm, on both sides of the floor
- 5 Metal pipe (with FEF insulation) with diameter of D and pipe wall thickness t

INTU FR COLLAR L	Annex F6 of European Technical Assessment ETA-19/0844
Construction details Metal pipe with insulation penetration seals in rigid floor	

Fig. F7. Plastic pipe without insulation penetration seals made with use of INTU FR SLEEVE in rigid floor

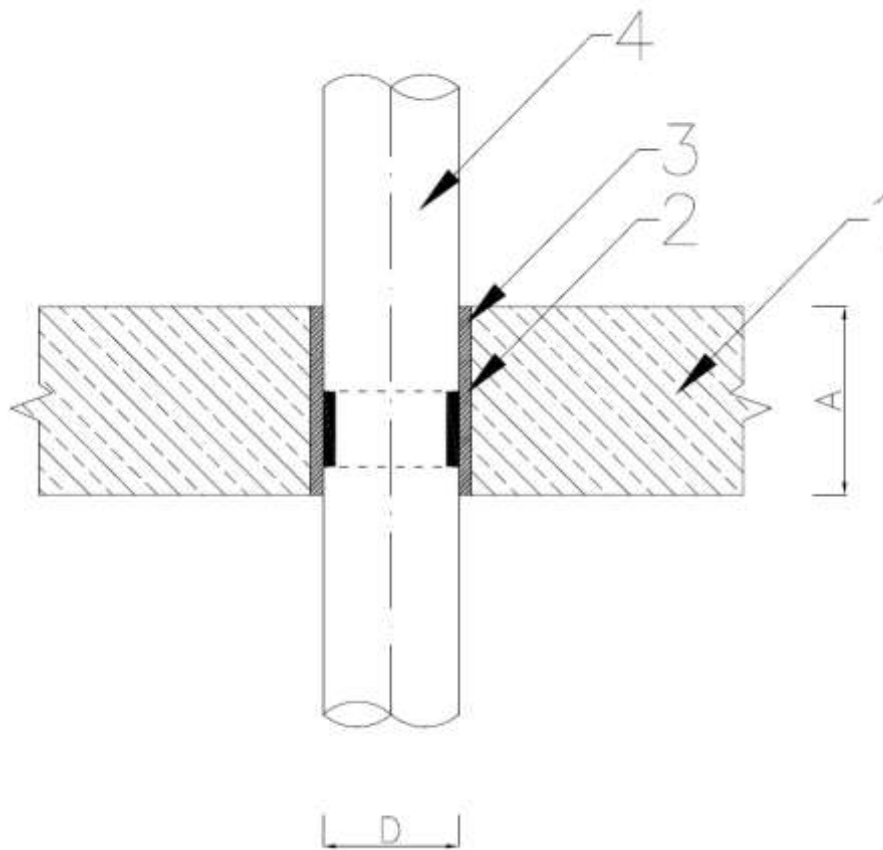

- 1 Rigid floor supporting construction with thickness in accordance with fire classification
- 2 INTU FR SLEEVE placed in the distance of 10 mm from the bottom of the floor; layers of intumescent material in accordance with fire classification
- 3 Space between the pipe and floor filled with cement mortar; ring with max. 25 mm width, on the whole depth of the floor
- 4 Plastic pipe with diameter of D and pipe wall thickness t

INTU FR SLEEVE

Construction details

Plastic pipe without insulation penetration seals in rigid floor

Annex F7
of European
Technical Assessment
ETA-19/0844