



INSTYTUT TECHNIKI BUDOWLANEJ



Member of



www.eota.eu

European Technical Assessment

**ETA-24/0152
of 22/12/2025**



General Part

Technical Assessment Body issuing the European Technical Assessment

Instytut Techniki Budowlanej

Trade name of the construction product

INTU FR GRAPHITE

Product family to which the construction product belongs

Fire Stopping and Fire Sealing Products.
Penetration Seals

Manufacturer

ALFASEAL GROUP Sp. z o.o.
ul. Kineskopowa 1
PL 05-500 Piaseczno, Poland

Manufacturing plant

Plant MPA2

This European Technical Assessment contains

26 pages including 3 Annexes which form an integral part of this Assessment

This European Technical Assessment is issued in accordance with regulation (EU) No 305/2011, on the basis of

European Assessment Document (EAD)
350454-00-1104 "Fire Stopping and Fire Sealing Products. Penetration Seals"

This version replaces

ETA-24/0152 issued on 28/03/2024



This European Technical Assessment is issued by the Technical Assessment Body in its official language. Translations of this European Technical Assessment in other languages shall fully correspond to the original issued document and shall be identified as such.

Communication of this European Technical Assessment, including transmission by electronic means, shall be in full. However, partial reproduction may only be made with the written consent of the issuing Technical Assessment Body. Any partial reproduction has to be identified as such.

Specific Part

1 Technical description of the product

INTU FR GRAPHITE is an intumescent mastic used to form penetration seals where pipes, cables and conduits penetrate walls and floors.

Auxiliary products used with INTU FR GRAPHITE to form single penetration seals are:

- Kaiflex ST synthetic, flexible elastomeric foam (FEF) in accordance with EN 14304,
- Tubolit DG Plus polyethylene foam (PE) insulation with nominal density of 30 kg/m³,
- Paroc Hvac Lamella Mat mineral wool board with nominal density of 35 kg/m³.

INTU FR GRAPHITE mastic assembly instruction is given in Annexes A to C.

2 Specification of the intended use in accordance with the applicable European Assessment Document (EAD)

2.1 Intended use

The intended use of INTU FR GRAPHITE mastic is to reinstate the fire resistance performance of flexible wall, rigid wall and rigid floor constructions, where they are penetrated by pipes, cables, conduits and bundles.

The specific elements of supporting construction that INTU FR GRAPHITE mastic may be used to provide a penetration seal in, are as follows:

Rigid walls: The wall must have a minimum thickness of 100 mm and comprise concrete or masonry separating elements, with a minimum density of 450 kg/m³.

Flexible walls: The wall must have a minimum thickness of 100 mm and comprise timber or steel studs lined on both faces with minimum two layers (with overall board layer thickness on one side equal to or greater than 25 mm) of 'Type F' or 'Type DF' gypsum plasterboards according to EN 520. In timber stud walls, no part of the penetration shall be closer than 100 mm to a stud, the cavity must be closed between the penetration seal and the stud and minimum 100 mm of insulation of reaction to fire class A1 or A2 according to EN 13501-1, is provided within the cavity between the penetration seal and the stud.

Rigid floors: The floor must have a minimum thickness of 150 mm and comprise aerated concrete, concrete and reinforced concrete, with a minimum density of 1700 kg/m³ – in case of penetration seals given in Annex B10.

The floor must have a minimum thickness of 150 mm and comprise aerated concrete, concrete and reinforced concrete, with a minimum density of 550 kg/m³ – in case of penetration seals given in Annex B11.

The supporting construction shall be classified in accordance with EN 13501-2 for the required fire resistance period (equal to or greater than specified in Annex B).

INTU FR GRAPHITE mastic may be used to provide a penetration seal with specific pipes, cables and conduits (according to Annexes A to C).

Construction details of penetration seals are provided in Annex C. Additional provisions are given in Annex A.

The provisions made in this European Technical Assessment are based on an assumed working life of the product of 25 years, when installed in the works, provided that the penetration seal is subject to appropriate installation, in accordance with the manufacturer's recommendations. The indications given on the working life cannot be interpreted as a guarantee given by the producer or the Technical Assessment Body, but are to be regarded only as a means for

choosing the right products in relation to the expected economically reasonable working life of the works.

2.2 Use category

Type Z₂: intended for use in internal conditions with humidity lower than 85% RH, excluding temperatures below 0°C, without exposure to rain or UV.

3 Performance of the product and references to the methods used for its assessment

3.1 Performance of the product

3.1.1 Safety in case of fire (BWR 2)

Essential characteristic	Performance
Reaction to fire	No performance assessed
Resistance to fire	Annex B

3.1.2 Hygiene, health and the environment (BWR 3)

No performance assessed.

3.1.3 Safety and accessibility in use (BWR 4)

Essential characteristic	Performance
Mechanical resistance and stability	No performance assessed
Resistance to impact / movement	No performance assessed
Adhesion	No performance assessed
Durability	Use category: Type Z ₂

3.1.4 Protection against noise (BWR 5)

No performance assessed.

3.1.5 Energy economy and heat retention (BWR 6)

No performance assessed.

3.2 Methods used for the assessment

The assessment has been made in accordance with EAD 350454-00-1104.

4 Assessment and verification of constancy of performance (AVCP) system applied, with reference to its legal base

According to the Decision 1999/454/EC of the European Commission, as amended by Decision 2001/596/EC of the European Commission, the system 1 of assessment and verification of constancy of performance applies (see Annex V to regulation (EU) No 305/2011).

5 Technical details necessary for the implementation of the AVCP system, as provided in the applicable European Assessment Document (EAD)

Technical details necessary for the implementation of the AVCP system are laid down in the control plan deposited in Instytut Techniki Budowlanej.

For type testing the results of the tests performed as part of the assessment for the European Technical Assessment shall be used unless there are changes in the production line or plant. In such cases the necessary type testing has to be agreed between Instytut Techniki Budowlanej and the notified body.

Issued in Warsaw on 22/12/2025 by Instytut Techniki Budowlanej

Anna Panek, MSc
Deputy Director of ITB

Additional provisions

- INTU FR GRAPHITE mastic shall be placed on one or both sides of the wall and on both sides of the floor.
- Classifications given in Annex B for cables are valid for small cables that are currently and commonly used in building practice in Europe, including optical fibre cables, except tied bundles, waveguides and non-sheathed cables (wires), in accordance with tables in Annex B.
- Distance from the surface of separating element to the cable or conduit support is max. 400 mm for first attachment.
- The penetration seals in round openings according to Annexes B3 to B6 are made for single cables, single cable bundles or single mixed bundles.
- The minimum distance between the adjacent penetration seals in flexible or rigid walls, given in Annex B, is:
 - 0 mm – for pipes without insulation, with diameter of $D \leq 20$ mm,
 - 100 mm – for pipes without insulation, with diameter of $D > 20$ mm,
 - 100 mm – for cables, conduits and bundles.
- The minimum distance between the adjacent penetration seals of pipes in rigid floors, given in Annexes B10 and B11, is 100 mm.
- The cable penetration seals given in Annex B3 are made in round openings with diameter of $D \leq 50$ mm, where the opening diameter shall be min. 5 mm greater than the cable diameter.
- The cable penetration seals given in Annex B4 are made in:
 - round openings with max. area of $0,0225$ m², where the opening diameter shall be min. 5 mm greater than the cable diameter (the area between the cable and opening edge is filled with mastic),
 - rectangular openings dimensions of max. 150 x 150 mm (width x height), wherein min. 5 mm of mastic shall be used on min. 2 side edges of the penetration seal opening.
- The penetration seals in rectangular openings given in Annex B4 are made for single cables and cable bundles or multiple cables and cable bundles. The minimum distance between the adjacent cables and between the cables and the seal edge is 0 mm.
- The mixed bundle penetration seals given in Annex B5 are made in round openings with diameter of $D \leq 100$ mm, where the opening diameter shall be min. 5 mm greater than the bundle diameter.
- The mixed bundle penetration seals given in Annex B6 and conduit penetration seals given in Annex B7 to B8 are made in:
 - round openings with max. area of $0,0225$ m², where the opening diameter shall be min. 5 mm greater than the bundle diameter (the area between the cable and opening edge is filled with mastic),
 - rectangular openings dimensions of max. 150 x 150 mm (width x height), where min. 5 mm of mastic shall be used on min. 2 side edges of the penetration seal opening.
- The penetration seals in round or rectangular openings given in Annex B7 and B8 are made for single conduits or multiple conduits. The minimum distance between the adjacent conduits and between the conduits and the seal edge is 0 mm.
- In Annex B8 to B9 the area inside the conduit (between the conduit wall inner surface or between the conduit wall inner surface and cables or cable bundles) is filled with INTU FR GRAPHITE mastic on the depth of min. 25 mm and mineral wool (Paroc Hvac Lamella Mat) backfill on the depth of min. 75 mm.

INTU FR GRAPHITE	Annex A of European Technical Assessment ETA-24/0152
Additional provisions	

- Classifications given in Annex B for cables are valid for:
 - small cables that are currently and commonly used in building practice in Europe, including optical fibre cables, except tied bundles, waveguides and non-sheathed cables (wires),
 - type F cables: A-2Y(L)2Y 20X2X0,6 according to DIN VDE 0816,
 - coaxial wireless AVA5-50FX cables according to EN 50575,
 - optical fiber cables Z-XOTKtsdD 24 x 9 / 125 cables according to ZN-TF-11:2011 or ZN-EK-103, in accordance with tables in Annex B.
- Classifications given in Annex B are valid for plastic pipes:
 - PVC-U according to EN 1329-1, EN 1453-1, EN ISO 1452-2, EN ISO 15493, DIN 8061, DIN 8062 or DIN 19531-10,
 - PVC-C according to EN 1566-1, EN ISO 15493 or EN ISO 15877-2,
 - PE according to EN 12201-2, EN 1519-1, EN 12666-1 or ISO 15494,
 - PE-HD according to EN 1519-1, EN 12666-1 or DIN 19535-10,
 - PE-X according to EN ISO 15875-2 or EN ISO 21003-1,
 - PE-RT according to EN ISO 21003-1,
 - PE-Xa according to EN ISO 21003-1,
 - PP according to EN 1451-1, DIN 8077, DIN 8078, DIN 16962, EN 15874-2 or EN ISO 15494,
 - PP-HT according to EN 1451-1 or EN 14758-1,
 - PP-R according to EN ISO 15874-2, DIN 8077 or DIN 8078,
 - ABS according to EN 1455-1 or EN ISO 15493,
 - SAN + PVC according to ISO 19220,
 - BlazeMaster CPVC with SDR 13,5, according to ASTM F442, according to tables in Annex B.
- Classifications given in Annex B are valid for MLC pipes:
 - PP-R/AL/PP-R according to EN ISO 23391-2, EN ISO 15874-1 or EN ISO 15874-2,
 - PE-X/AL/PE-X according to EN ISO 21003-2,
 - PE-RT/AL/PE-RT according to EN ISO 21003-2, according to tables in Annex B.
- Classifications given in Annex B are valid for composite pipes PP-R/PP-R-GF/PP-R according to EN ISO 15874-1 or EN ISO 15874-2, according to tables in Annex B.
- Classifications given in Annex B for copper pipes and steel conduits are also valid for other metal pipe materials with:
 - thermal conductivity lower than respectively copper and steel, and
 - melting point at least equal to respectively steel, and greater than:
 - 739 °C for the fire resistance class EI 15 and E 15,
 - 781 °C for the fire resistance class EI 20 and E 20,
 - 842 °C for the fire resistance class EI 30 and E 30,
 - 902 °C for the fire resistance class EI 45 and E 45,
 - 945 °C for the fire resistance class EI 60 and E 60,
 - 1006 °C for the fire resistance class EI 90 and E 90,
 - 1049 °C for the fire resistance class EI 120 and E 120,
 - 1110 °C for the fire resistance class EI 180 and E 180,
 - 1153 °C for the fire resistance class EI 240 and E 240.
- Classifications given in Annex B are valid for specific conduits:
 - PVC according to EN 61386-21,
 - AROT DVK Wavin, according to tables in Annex B.
- Distance from the surface of separating element to the pipes, cables, conduits and mixed bundles support is max. 400 mm for first attachment.

INTU FR GRAPHITE	Annex A of European Technical Assessment ETA-24/0152
Additional provisions	

Table B1. Resistance to fire classification of plastic, MLC and composite pipes (without insulation) penetration seals in flexible or rigid wall, made with use of INTU FR GRAPHITE placed on both sides of the wall on the depth of 25,0 mm, without backfilling material, in accordance with Annex A and Annex C1

Pipe material	Pipe diameter [mm]	Pipe wall thickness [mm]	Number x depth x width of INTU FR GRAPHITE [mm]	Fire resistance class	
PE-HD / PE / PE-X / ABS / SAN+PVC	D ≤ 32	1,8 – 6,8	2 x 25,0 x 10,0 – 20,0	EI 120-U/C EI 120-C/C	
	32 < D ≤ 50	2,3 – 6,8	2 x 25,0 x 10,0 – 20,0		
	50 < D ≤ 75	3,0 – 6,8	2 x 25,0 x 10,0 – 20,0		
	D ≤ 75	6,9 – 10,0	2 x 25,0 x 10,0 – 20,0	EI 90-U/C EI 90-C/C	
	75 < D ≤ 110		4,2 – 9,9	2 x 25,0 x 10,0 – 20,0	EI 60-U/C EI 60-C/C
10,0			2 x 25,0 x 10,0 – 20,0	EI 90-U/C EI 90-C/C	
PP	D ≤ 50	1,8 – 18,3	2 x 25,0 x 10,0 – 20,0	EI 120-U/C EI 120-C/C	
	50 < D ≤ 75	1,9 – 18,3	2 x 25,0 x 10,0 – 20,0		
	75 < D ≤ 90	2,3 – 18,3	2 x 25,0 x 10,0 – 20,0		
	90 < D ≤ 110	2,7 – 18,3	2 x 25,0 x 10,0 – 20,0		
PVC-U / PVC-C	D ≤ 32	1,5 – 8,1	2 x 25,0 x 10,0 – 20,0	EI 120-U/C EI 120-C/C	
	32 < D ≤ 50	1,6 – 8,1	2 x 25,0 x 10,0 – 20,0		
	50 < D ≤ 75	1,8 – 8,1	2 x 25,0 x 10,0 – 20,0		
	75 < D ≤ 110		2,0 – 8,0	2 x 25,0 x 10,0 – 20,0	EI 90-U/C EI 90-C/C
			8,1	2 x 25,0 x 10,0 – 20,0	EI 120-U/C EI 120-C/C
PE-RT/AL/PE-RT (MLC)	D ≤ 20	2,0 – 6,0	2 x 25,0 x 10,0 – 20,0	EI 120-U/C EI 120-C/C	
		6,1 – 7,5	2 x 25,0 x 10,0 – 20,0	EI 60 / E 120-U/C EI 60 / E 120-C/C	
	20 < D ≤ 32	3,1	2 x 25,0 x 10,0 – 20,0	EI 120-U/C EI 120-C/C	
	32 < D ≤ 40	3,9	2 x 25,0 x 10,0 – 20,0		
	40 < D ≤ 50	4,8	2 x 25,0 x 10,0 – 20,0		
	50 < D ≤ 63	6,0	2 x 25,0 x 10,0 – 20,0	EI 60 / E 120-U/C EI 60 / E 120-C/C	
	63 < D ≤ 75	7,5	2 x 25,0 x 10,0 – 20,0		
PE-X/AL/PE-X (MLC)	D ≤ 20	2,0 – 6,0	2 x 25,0 x 10,0 – 20,0	EI 120-U/C EI 120-C/C	
	20 < D ≤ 32	3,1	2 x 25,0 x 10,0 – 20,0		
	32 < D ≤ 40	3,9	2 x 25,0 x 10,0 – 20,0		
	40 < D ≤ 50	4,8	2 x 25,0 x 10,0 – 20,0		
	50 < D ≤ 63	6,0	2 x 25,0 x 10,0 – 20,0		
PE-Xa	D ≤ 20	2,0 – 5,8	2 x 25,0 x 10,0 – 20,0	EI 120-U/C EI 120-C/C	
	20 < D ≤ 32	3,0	2 x 25,0 x 10,0 – 20,0		
	32 < D ≤ 40	3,8	2 x 25,0 x 10,0 – 20,0		
	40 < D ≤ 50	4,6	2 x 25,0 x 10,0 – 20,0		
	50 < D ≤ 63	5,8	2 x 25,0 x 10,0 – 20,0		

wall thickness ≥ 100 mm

INTU FR GRAPHITE

Penetration seals made with use of INTU FR GRAPHITE
Plastic, MLC and composite pipes (without insulation) penetration seals in flexible or rigid wall

Annex B1
of European
Technical Assessment
ETA-24/0152

Table B2 (cont. Table B1). Resistance to fire classification of plastic, MLC and composite pipes (without insulation) penetration seals in flexible or rigid wall, made with use of INTU FR GRAPHITE placed on both sides of the wall on the depth of 25,0 mm, without backfilling material in accordance with Annex A and Annex C1

Pipe material	Pipe diameter [mm]	Pipe wall thickness [mm]	Number x depth x width of INTU FR GRAPHITE [mm]	Fire resistance class
PP-R	D ≤ 20	2,3 – 10,0	2 x 25,0 x 10,0 – 20,0	EI 120-U/C EI 120-C/C
	20 < D ≤ 32	3,3 – 12,5	2 x 25,0 x 10,0 – 20,0	
	32 < D ≤ 50	4,8 – 12,5	2 x 25,0 x 10,0 – 20,0	
	50 < D ≤ 63	5,8 – 12,5	2 x 25,0 x 10,0 – 20,0	
	63 < D ≤ 75	6,8 – 12,5	2 x 25,0 x 10,0 – 20,0	EI 90-U/C EI 90-C/C
	20 < D ≤ 32	12,6 – 16,0	2 x 25,0 x 10,0 – 20,0	
	32 < D ≤ 75	12,6 – 18,3	2 x 25,0 x 10,0 – 20,0	
	75 < D ≤ 90	8,2 – 10,0	2 x 25,0 x 10,0 – 20,0	EI 120-U/C
	90 < D ≤ 110	10,0	2 x 25,0 x 10,0 – 20,0	EI 120-C/C
75 < D ≤ 110	10,1 – 18,3	2 x 25,0 x 10,0 – 20,0	EI 90-U/C EI 90-C/C	
PP-R/AL/PP-R (MLC)	D ≤ 20	2,8 – 10,0	2 x 25,0 x 10,0 – 20,0	EI 120-U/C EI 120-C/C
	20 < D ≤ 32	4,4 – 16,0	2 x 25,0 x 10,0 – 20,0	
	32 < D ≤ 50	6,9 – 18,3	2 x 25,0 x 10,0 – 20,0	
	50 < D ≤ 63	8,6 – 18,3	2 x 25,0 x 10,0 – 20,0	
	63 < D ≤ 75	10,3 – 18,3	2 x 25,0 x 10,0 – 20,0	EI 90-U/C EI 90-C/C
	75 < D ≤ 90	12,3 – 14,9	2 x 25,0 x 10,0 – 20,0	
		15,0 – 18,3	2 x 25,0 x 10,0 – 20,0	
	90 < D ≤ 110	15,1 – 18,2	2 x 25,0 x 10,0 – 20,0	EI 90-U/C EI 90-C/C
		18,3	2 x 25,0 x 10,0 – 20,0	EI 120-U/C EI 120-C/C
PP-R/PP-R-GF/PP-R (composite)	D ≤ 20	2,8 – 10,0	2 x 25,0 x 10,0 – 20,0	EI 120-U/C EI 120-C/C
	20 < D ≤ 32	4,4 – 16,0	2 x 25,0 x 10,0 – 20,0	
	32 < D ≤ 50	6,9 – 18,3	2 x 25,0 x 10,0 – 20,0	
	50 < D ≤ 63	8,6 – 18,3	2 x 25,0 x 10,0 – 20,0	
	63 < D ≤ 75	10,3 – 18,3	2 x 25,0 x 10,0 – 20,0	
	75 < D ≤ 90	12,3 – 18,3	2 x 25,0 x 10,0 – 20,0	
90 < D ≤ 110	15,1 – 18,3	2 x 25,0 x 10,0 – 20,0		
BlazeMaster CPVC	D ≤ 19,0	2,24 – 3,38	2 x 25,0 x 10,0 – 20,0	EI 120-U/C EI 120-C/C
	19,0 < D ≤ 25,4	2,71 – 3,38	2 x 25,0 x 10,0 – 20,0	
	25,4 < D ≤ 31,8	3,38	2 x 25,0 x 10,0 – 20,0	
	D ≤ 31,8	3,39 – 3,84	2 x 25,0 x 10,0 – 20,0	EI 90-U/C
	31,8 < D ≤ 38,1	3,84	2 x 25,0 x 10,0 – 20,0	EI 90-C/C

wall thickness ≥ 100 mm

INTU FR GRAPHITE

Penetration seals made with use of INTU FR GRAPHITE
Plastic, MLC and composite pipes (without insulation) penetration seals in flexible or rigid wall

Annex B2
of European
Technical Assessment
ETA-24/0152

Table B3. Resistance to fire classification of following types of cables penetration seals in flexible or rigid wall, made in accordance with Annex A and Annex C2:

- type F cable: A-2Y(L)2Y 20x2x0,6,
- single coaxial wireless cable type AVA5-50FX ($\varnothing_{\text{cable}} \leq 22,23$ mm),

made with use of INTU FR GRAPHITE placed on both sides of the wall on the depth of 25,0 mm, without backfilling material

Fire resistance class: EI 120

wall thickness ≥ 100 mm

INTU FR GRAPHITE

Penetration seals made with use of INTU FR GRAPHITE
Cable penetration seals in flexible or rigid wall

Annex B3
of European
Technical Assessment
ETA-24/0152

Table B4. Resistance to fire classification of following types of cables penetration seals in flexible or rigid wall, made in accordance with Annex A and Annex C3:

- **small cable** ($\varnothing_{\text{cable}} \leq 21 \text{ mm}$), including optical fiber cable,
- **cable bundle** ($\varnothing_{\text{bundle}} \leq 100 \text{ mm}$, $\varnothing_{\text{cable}} \leq 21 \text{ mm}$),

made with use of INTU FR GRAPHITE placed on both sides of the wall on the depth of 25,0 mm, with mineral wool Paroc Hvac Lamella Mat backfilling material

Fire resistance class: EI 120

wall thickness $\geq 100 \text{ mm}$

INTU FR GRAPHITE

Penetration seals made with use of INTU FR GRAPHITE
Cable penetration seals in flexible or rigid wall

Annex B4
of European
Technical Assessment
ETA-24/0152

Table B5. Resistance to fire classification of penetration seals in flexible or rigid wall, made in accordance with Annex A and Annex C4, of following mixed bundle:

- max. 2 x copper / steel pipe (C/U, C/C pipe end configuration) diameter of $D \leq 12,7$ mm and pipe wall thickness $\geq 0,8$ mm, with flexible elastomeric foam (FEF) continuous insulation (case CS) type Kaiflex ST, thickness of 13 mm,
- max. 1 x copper / steel pipe (C/U, C/C pipe end configuration) diameter of $D \leq 28,6$ mm and pipe wall thickness $\geq 1,0$ mm, with flexible elastomeric foam (FEF) continuous insulation (case CS) type Kaiflex ST, thickness of 13 mm,
- max. 1 x PVC-U pipe (U/U, U/C, C/U, C/C pipe end configuration) without insulation, diameter of: $D \leq 25$ mm and pipe wall thickness 1,0 mm,
- max. 1 x single cable 4 x 1,5 mm²,

made with use of INTU FR GRAPHITE placed on both sides of the wall on the depth of 25,0 mm, without backfilling material

Fire resistance class: EI 120

wall thickness ≥ 100 mm

INTU FR GRAPHITE

Penetration seals made with use of INTU FR GRAPHITE
Mixed bundle penetration seals in flexible or rigid wall

Annex B5
of European
Technical Assessment
ETA-24/0152

Table B6. Resistance to fire classification of penetration seals in flexible or rigid wall, made in accordance with Annex A and Annex C5, of following mixed bundle:

- max. 4 x copper / steel pipe (C/U, C/C pipe end configuration) diameter of $D \leq 12,7$ mm and pipe wall thickness $\geq 0,8$ mm, with polyethylene foam (PE) continuous insulation (case CS) type Tubolit DG PLUS, thickness of 9 mm
- max. 2 x copper / steel pipe (C/U, C/C pipe end configuration) diameter of $D \leq 22,3$ mm and pipe wall thickness $\geq 1,0$ mm, with polyethylene foam (PE) continuous insulation (case CS) type Tubolit DG PLUS, thickness of 9 mm,
- max. 2 x copper / steel pipe (C/U, C/C pipe end configuration) diameter of $D \leq 28,6$ mm and pipe wall thickness $\geq 1,0$ mm, with polyethylene foam (PE) continuous insulation (case CS) type Tubolit DG PLUS, thickness of 13 mm,
- max. 2 x PVC-U pipe (U/U, U/C, C/U, C/C pipe end configuration) without insulation, diameter of: $D \leq 25$ mm and pipe wall thickness 1,0 mm,
- max. 2 x single cable 4 x 1,5 mm²,

made with use of INTU FR GRAPHITE placed on both sides of the wall on the depth of 25,0 mm, without backfilling material

Fire resistance class: EI 60 / E 120
wall thickness ≥ 100 mm

INTU FR GRAPHITE	Annex B6 of European Technical Assessment ETA-24/0152
Penetration seals made with use of INTU FR GRAPHITE Mixed bundle penetration seals in flexible or rigid wall	

Table B7. Resistance to fire classification of steel conduits ($\varnothing_{\text{conduit}} \leq 16,0$ mm) penetration seals in flexible or rigid wall, made in accordance with Annex A and Annex C6, made with use of INTU FR GRAPHITE (outside the conduit) placed on both sides of the wall on the depth of 25,0 mm, with mineral wool Paroc Hvac Lamella Mat backfilling material

Fire resistance class:
EI 120-C/U
EI 120-C/C

wall thickness ≥ 100 mm

INTU FR GRAPHITE

Penetration seals made with use of INTU FR GRAPHITE
 Metal conduit penetration seals in flexible or rigid wall

Annex B7
 of European
 Technical Assessment
 ETA-24/0152

Table B8. Resistance to fire classification of PVC conduits with or without small cables ($\varnothing_{\text{cable}} \leq 21$ mm) or cable bundle ($\varnothing_{\text{bundle}} \leq$ conduit inner diameter, $\varnothing_{\text{cable}} \leq 21$ mm) penetration seals in flexible or rigid wall, made in accordance with Annex A and Annex C6, made with use of INTU FR GRAPHITE (outside the conduit) placed on both sides of the wall on the depth of 25,0 mm, with mineral wool Paroc Hvac Lamella Mat backfilling material

Conduit diameter [mm]	Conduit wall thickness [mm]	Service inside	Depth of INTU FR GRAPHITE [mm]	Fire resistance class
D ≤ 16	0,85 – 1,50	empty	2 x 25,0	EI 120-U/U EI 120-U/C EI 120-C/U EI 120-C/C
		small cable: $\varnothing_{\text{cable}} \leq D_{\text{in}}^{1)}$	2 x 25,0	
		cable bundle: $\varnothing_{\text{bundle}} \leq D_{\text{in}}^{1)}$ $\varnothing_{\text{cable}} \leq D_{\text{in}}^{1)}$	2 x 25,0	
16 < D ≤ 25	1,05 – 1,50	empty	2 x 25,0	EI 120-U/U EI 120-U/C EI 120-C/U EI 120-C/C
		small cable: $\varnothing_{\text{cable}} \leq 21$ mm	2 x 25,0	
		cable bundle: $\varnothing_{\text{bundle}} \leq D_{\text{in}}^{1)}$ $\varnothing_{\text{cable}} \leq 21$ mm	2 x 25,0	
25 < D ≤ 37	1,50	empty	2 x 25,0	EI 120-U/U EI 120-U/C EI 120-C/U EI 120-C/C
		small cable: $\varnothing_{\text{cable}} \leq 21$ mm	2 x 25,0	
		cable bundle: $\varnothing_{\text{bundle}} \leq D_{\text{in}}^{1)}$ $\varnothing_{\text{cable}} \leq 21$ mm	2 x 25,0	
¹⁾ D _{in} – conduit inner diameter				
wall thickness ≥ 100 mm				

INTU FR GRAPHITE

Penetration seals made with use of INTU FR GRAPHITE
 Plastic conduit penetration seals in flexible or rigid wall

Annex B8
 of European
 Technical Assessment
 ETA-24/0152

Table B9. Resistance to fire classification of AROT DVK conduits with or without small cables ($\varnothing_{\text{cable}} \leq 21$ mm) or cable bundle ($\varnothing_{\text{bundle}} \leq$ conduit inner diameter, $\varnothing_{\text{cable}} \leq 21$ mm) penetration seals in flexible or rigid wall, made in accordance with Annex A and Annex C7, made with use of INTU FR GRAPHITE (inside the conduit) placed on one side of the wall on the depth of 25,0 mm, with mineral wool Paroc Hvac Lamella Mat backfilling material on the depth of 25,0 mm

Conduit diameter [mm]	Conduit wave height [mm]	Service inside	Depth of INTU FR GRAPHITE [mm]	Fire resistance class
D ≤ 100	3,0	empty	2 x 25,0	EI 90 / E 120-U/C EI 90 / E 120-C/C
		small cable: $\varnothing_{\text{cable}} \leq 21$ mm	2 x 25,0	EI 90 / E 120-U/C EI 90 / E 120-C/C
		cable bundle: $\varnothing_{\text{bundle}} \leq D_{\text{in}}^{1)}$ $\varnothing_{\text{cable}} \leq 21$ mm	2 x 25,0	EI 90 / E 120-U/C EI 90 / E 120-C/C

¹⁾ D_{in} – conduit inner diameter

wall thickness ≥ 100 mm

INTU FR GRAPHITE

Penetration seals made with use of INTU FR GRAPHITE
Plastic conduit penetration seals in flexible or rigid wall

Annex B9
of European
Technical Assessment
ETA-24/0152

Table B10. Resistance to fire classification of plastic pipes (without insulation) penetration seals in rigid floor, made in accordance with Annex A and Annex C8

Pipe material	Pipe diameter [mm]	Pipe wall thickness [mm]	Number x depth x width of INTU FR GRAPHITE [mm]	Fire resistance class
PE-HD / PE / PE-X / ABS / SAN+PVC	$D \leq 32$	1,8 – 10,0	2 x 25,0 x 10,0 – 20,0	EI 120-U/C EI 120-C/C
	$32 < D \leq 50$	2,3 – 10,0	2 x 25,0 x 10,0 – 20,0	
	$50 < D \leq 75$	3,0 – 10,0	2 x 25,0 x 10,0 – 20,0	
	$75 < D \leq 90$	3,5 – 10,0	2 x 25,0 x 10,0 – 20,0	
	$90 < D \leq 110$	4,2 – 10,0	2 x 25,0 x 10,0 – 20,0	
PP	$D \leq 50$	1,8 – 18,3	2 x 25,0 x 10,0 – 20,0	EI 120-U/C EI 120-C/C
	$50 < D \leq 75$	1,9 – 18,3	2 x 25,0 x 10,0 – 20,0	
	$75 < D \leq 110$	2,7 – 18,3	2 x 25,0 x 10,0 – 20,0	
PVC-U / PVC-C	$D \leq 32$	1,5 – 8,1	2 x 25,0 x 10,0 – 20,0	EI 120-U/C EI 120-C/C
	$32 < D \leq 50$	1,6 – 8,1	2 x 25,0 x 10,0 – 20,0	
	$50 < D \leq 75$	1,8 – 8,1	2 x 25,0 x 10,0 – 20,0	
	$75 < D \leq 110$	2,0 – 8,1	2 x 25,0 x 10,0 – 20,0	

 floor thickness ≥ 150 mm, density ≥ 1700 kg/m³
INTU FR GRAPHITE
Penetration seals made with use of INTU FR GRAPHITE
 Plastic pipes (without insulation) penetration seals in rigid floor

Annex B10
 of European
 Technical Assessment
 ETA-24/0152

Table B11. Resistance to fire classification of plastic, MLC and composite pipes (without insulation) penetration seals in rigid floor, made in accordance with Annex A and Annex C8

Pipe material	Pipe diameter [mm]	Pipe wall thickness [mm]	Number x depth x width of INTU FR GRAPHITE [mm]	Fire resistance class
PE-RT/AL/PE-RT (MLC)	D ≤ 20	2,0 – 7,5	2 x 25,0 x 10,0 – 20,0	EI 120-U/C EI 120-C/C
	20 < D ≤ 32	3,1	2 x 25,0 x 10,0 – 20,0	
	32 < D ≤ 40	3,9	2 x 25,0 x 10,0 – 20,0	
	40 < D ≤ 50	4,8	2 x 25,0 x 10,0 – 20,0	
	50 < D ≤ 63	6,0	2 x 25,0 x 10,0 – 20,0	
PE-X/AL/PE-X (MLC)	D ≤ 20	2,0 – 6,0	2 x 25,0 x 10,0 – 20,0	EI 120-U/C EI 120-C/C
	20 < D ≤ 32	3,1	2 x 25,0 x 10,0 – 20,0	
	32 < D ≤ 40	3,9	2 x 25,0 x 10,0 – 20,0	
	40 < D ≤ 50	4,8	2 x 25,0 x 10,0 – 20,0	
PE-Xa	D ≤ 20	2,0 – 5,8	2 x 25,0 x 10,0 – 20,0	EI 120-U/C EI 120-C/C
	20 < D ≤ 32	3,1	2 x 25,0 x 10,0 – 20,0	
	32 < D ≤ 40	3,9	2 x 25,0 x 10,0 – 20,0	
	40 < D ≤ 50	4,8	2 x 25,0 x 10,0 – 20,0	
PP-R	D ≤ 20	2,3 – 10,0	2 x 25,0 x 10,0 – 20,0	EI 120-U/C EI 120-C/C
	20 < D ≤ 32	3,3 – 16,0	2 x 25,0 x 10,0 – 20,0	
	32 < D ≤ 50	4,8 – 18,3	2 x 25,0 x 10,0 – 20,0	
	50 < D ≤ 63	5,8 – 18,3	2 x 25,0 x 10,0 – 20,0	
	63 < D ≤ 75	6,8 – 18,3	2 x 25,0 x 10,0 – 20,0	
	75 < D ≤ 90	8,3 – 18,3	2 x 25,0 x 10,0 – 20,0	
PP-R/AL/PP-R (MLC)	D ≤ 20	2,3 – 10,0	2 x 25,0 x 10,0 – 20,0	EI 120-U/C EI 120-C/C
	20 < D ≤ 32	4,0 – 16,0	2 x 25,0 x 10,0 – 20,0	
	32 < D ≤ 50	6,7 – 18,3	2 x 25,0 x 10,0 – 20,0	
	50 < D ≤ 63	8,6 – 18,3	2 x 25,0 x 10,0 – 20,0	
	63 < D ≤ 75	10,3 – 18,3	2 x 25,0 x 10,0 – 20,0	
	75 < D ≤ 90	12,3 – 18,3	2 x 25,0 x 10,0 – 20,0	
PP-R/PP-R-GF/PP-R (composite)	D ≤ 20	2,8 – 10,0	2 x 25,0 x 10,0 – 20,0	EI 120-U/C EI 120-C/C
	20 < D ≤ 32	4,4 – 16,0	2 x 25,0 x 10,0 – 20,0	
	32 < D ≤ 50	6,9 – 18,3	2 x 25,0 x 10,0 – 20,0	
	50 < D ≤ 63	8,6 – 18,3	2 x 25,0 x 10,0 – 20,0	
	63 < D ≤ 75	10,3 – 18,3	2 x 25,0 x 10,0 – 20,0	
	75 < D ≤ 90	12,3 – 18,3	2 x 25,0 x 10,0 – 20,0	
floor thickness ≥ 150 mm, density ≥ 550 kg/m ³				

INTU FR GRAPHITE

Penetration seals made with use of INTU FR GRAPHITE
Plastic, MLC and composite pipes (without insulation) penetration seals in rigid floor

Annex B11
of European
Technical Assessment
ETA-24/0152

Fig. C1. Plastic, MLC and composite pipes (without insulation) penetration seal in flexible or rigid wall made with use of INTU FR GRAPHITE

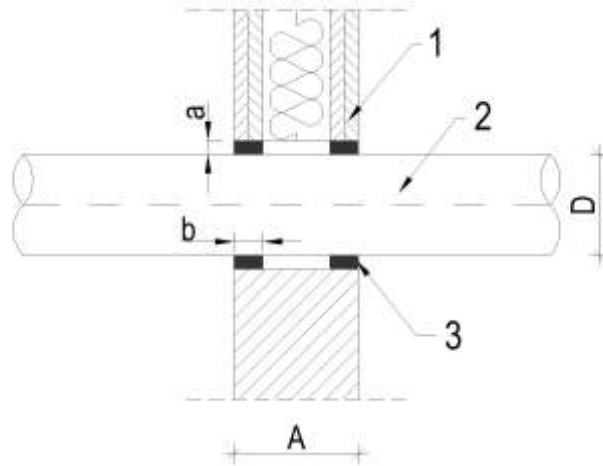

- 1 Flexible or rigid wall supporting construction thickness of $A \geq 100$ mm
- 2 Plastic, MLC and composite pipe, diameter of "D"
- 3 INTU FR GRAPHITE mastic (area between the pipe and supporting construction, ring with width of $a = 10 - 20$ mm, mastic minimum depth of $b = 25$ mm, on both sides of the wall)

INTU FR GRAPHITE

Construction details

Plastic, MLC and composite pipes without insulation penetration seals in flexible or rigid wall

Annex C1
of European
Technical Assessment
ETA-24/0152

Fig. C2. Cable penetration seal in flexible or rigid wall made with use of INTU FR GRAPHITE

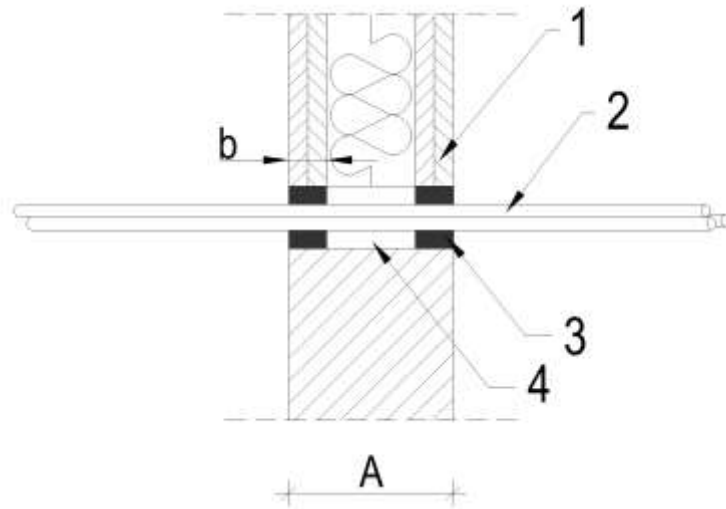

- 1 Flexible or rigid wall supporting construction thickness of $A \geq 100$ mm
- 2 Single cable
- 3 INTU FR GRAPHITE mastic (area between the pipe and supporting construction, mastic minimum depth of $b = 25$ mm, on both sides of the wall)
- 4 Empty space

INTU FR GRAPHITE

Construction details
Cable penetration seals in flexible or rigid wall

Annex C2
of European
Technical Assessment
ETA-24/0152

Fig. C3. Cable or cable bundle penetration seal in flexible or rigid wall made with use of INTU FR GRAPHITE

a) single small cable or cable bundle

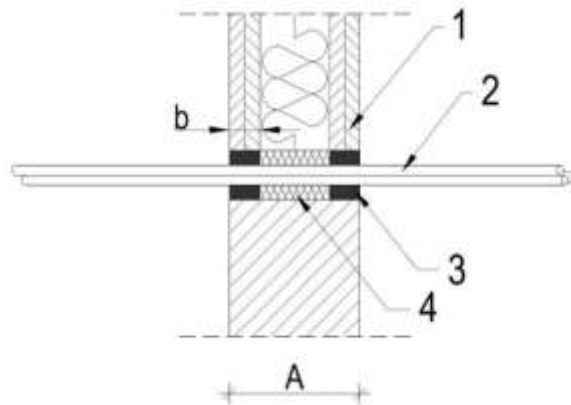

b) single small cable and cable bundle

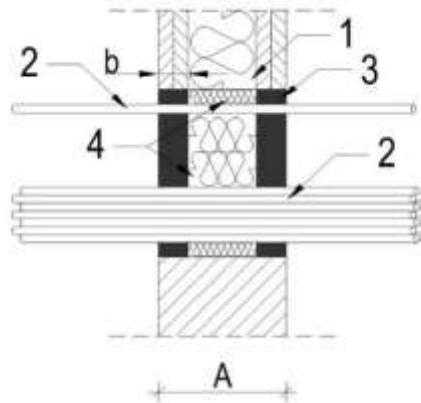

- 1 Flexible or rigid wall supporting construction thickness of $A \geq 100$ mm
- 2 Single small cable or cable bundle
- 3 INTU FR GRAPHITE mastic (area between the pipe and supporting construction, mastic minimum depth of $b = 25$ mm, on both sides of the wall)
- 4 Mineral wool type Paroc Hvac Lamella Mat with density of 35 kg/m^3 , underlay filling remaining area in the opening between two sides of INTU FR GRAPHITE mastic

INTU FR GRAPHITE	Annex C3 of European Technical Assessment ETA-24/0152
Construction details Cable or cable bundle penetration seals in flexible or rigid wall	

Fig. C4. Mixed bundle with flexible elastomeric foam (FEF) continuous insulation penetration seal in flexible or rigid wall made with use of INTU FR GRAPHITE

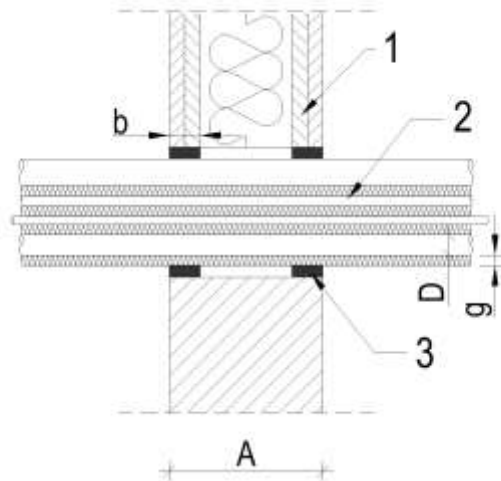

- 1 Flexible or rigid wall supporting construction thickness of $A \geq 100$ mm
- 2 Bundle of pipes and cable: 3 x copper pipe with continuous flexible elastomeric foam (FEF) insulation type Kaiflex ST (thickness of FEF insulation "g"), 1 x PVC-U pipe and 1 x cable $4 \times 1,5$ mm²; pipe diameter of "D"
- 3 INTU FR GRAPHITE mastic (area between the pipe and supporting construction, mastic minimum depth of $b = 25$ mm, on both sides of the wall)

INTU FR GRAPHITE

Construction details

Mixed bundle with flexible elastomeric foam (FEF) insulation penetration seals in flexible or rigid wall

Annex C4
of European
Technical Assessment
ETA-24/0152

Fig. C5. Mixed bundle with polyethylene foam (PE) continuous insulation penetration seal in flexible or rigid wall made with use of INTU FR GRAPHITE

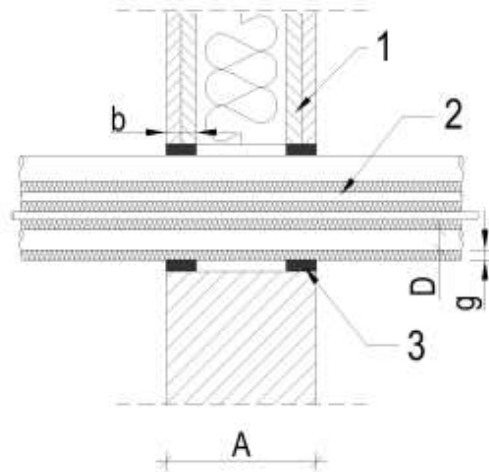

- 1 Flexible or rigid wall supporting construction thickness of $A \geq 100$ mm
- 2 Bundle of pipes and cable: 8 x copper pipe with continuous polyethylene foam (PE) insulation type Tubolit DG PLUS (thickness of PE insulation "g"), 2 x PVC-U pipe and 2 x cable 4 x 1,5 mm²; pipe diameter of "D"
- 3 INTU FR GRAPHITE mastic (area between the pipe and supporting construction, mastic minimum depth of $b = 25$ mm, on both sides of the wall)

INTU FR GRAPHITE

Construction details

Mixed bundle with polyethylene foam (PE) insulation penetration seals in flexible or rigid wall

Annex C5
of European
Technical Assessment
ETA-24/0152

Fig. C6. Plastic and metal conduit penetration seal in flexible or rigid wall made with use of INTU FR GRAPHITE

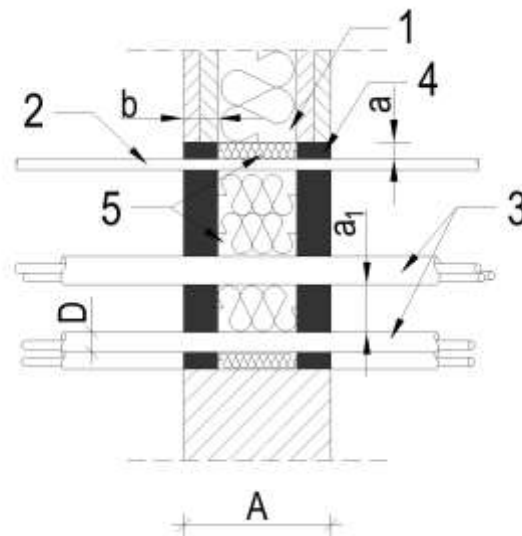

- 1 Flexible or rigid wall supporting construction thickness of $A \geq 100$ mm
- 2 Metal conduit without cables
- 3 Plastic conduit with or without small cables inside, conduit diameter of "D"
- 4 INTU FR GRAPHITE mastic (area between the pipe and supporting construction, mastic minimum depth of $b = 25$ mm, on both sides of the wall)
- 5 Mineral wool type Paroc Hvac Lamella Mat with density of 35 kg/m^3 , underlay filling remaining area in the opening between two sides of INTU FR GRAPHITE mastic
- a Distance between conduit surface and partition edge: $a \geq 0$ mm
- a1 Distance between the edges of conduits: $a1 \geq 0$ mm

INTU FR GRAPHITE

Construction details

Plastic and metal conduit penetration seals in flexible or rigid wall

Annex C6
of European
Technical Assessment
ETA-24/0152

Fig. C7. Plastic conduit penetration seal in flexible or rigid wall made with use of INTU FR GRAPHITE

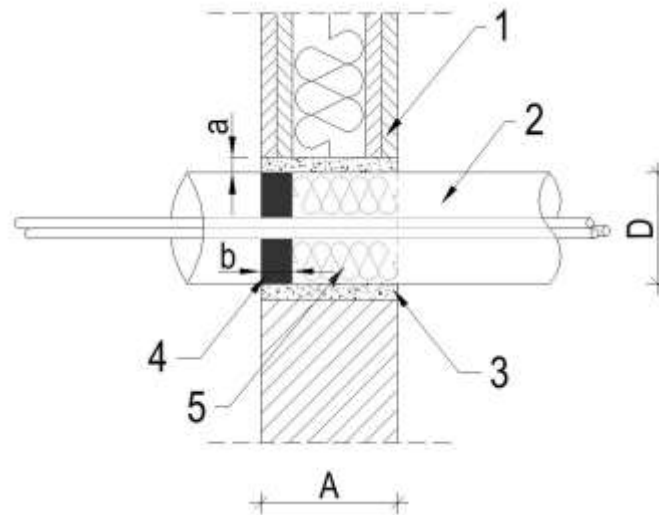

- 1 Flexible or rigid wall supporting construction thickness of $A \geq 100$ mm
- 2 Plastic conduit with or without small cables inside (protruding max. 50 mm from the wall surface), conduit diameter of "D"
- 3 Gap filled with gypsum or cement mortar, ring with max. width $a = 20$ mm, on the whole thickness of the wall
- 4 INTU FR GRAPHITE mastic (area between the cables and conduit inner wall, mastic minimum depth of $b = 25$ mm, on one side of the wall)
- 5 Mineral wool type Paroc Hvac Lamella Mat with density of 35 kg/m^3 , on the minimum depth of 75 mm

INTU FR GRAPHITE

Construction details

Plastic conduit penetration seals in flexible or rigid wall

Annex C7
of European
Technical Assessment
ETA-24/0152

Fig. C8. Plastic, MLC and composite pipes (without insulation) penetration seal in rigid floor made with use of INTU FR GRAPHITE

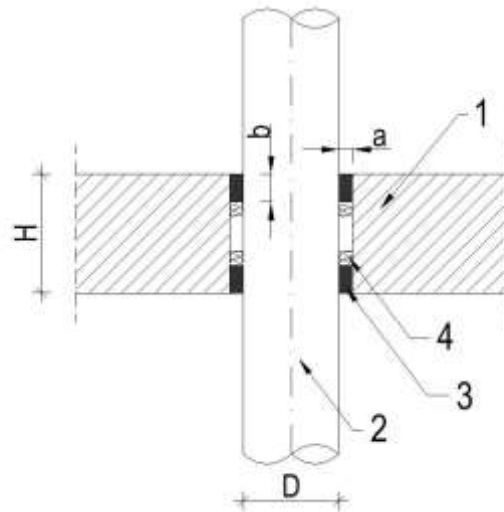

- 1 Rigid floor supporting construction thickness of $H \geq 150$ mm
- 2 Plastic, MLC and composite pipe, diameter of "D"
- 3 INTU FR GRAPHITE mastic (area between the pipe and supporting construction, ring with width of $a = 10 - 20$ mm, mastic minimum depth of $b = 25$ mm, on both sides of the floor)
- 4 Mineral wool type Paroc Hvac Lamella Mat AluCoat, density of 35 kg/m^3 , backfilling material with min. depth of 15 mm

INTU FR GRAPHITE

Construction details

Plastic, MLC and composite pipes without insulation penetration seals in rigid floor

Annex C8
of European
Technical Assessment
ETA-24/0152