

INTU FR BRICK

Intumescent fire stop brick

TDS TECHNICAL DATA SHEET

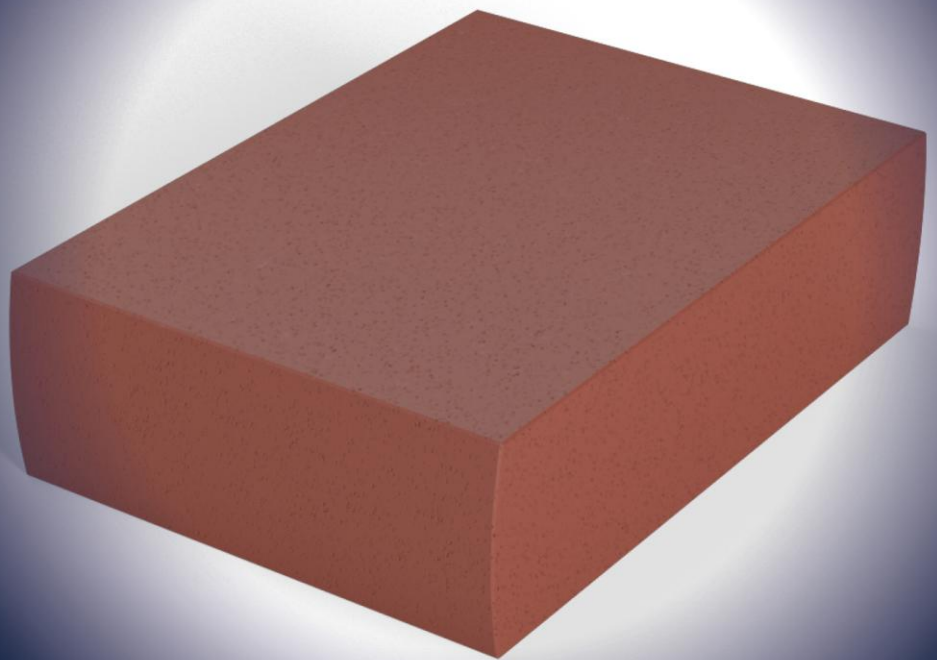

CE



E_UTA

INTU FR BRICK

Intumescent fire stop brick

TDS TECHNICAL DATA SHEET

→ PRODUCT DESCRIPTION

Fire protection block **INTU FR BRICK** is made of intumescent polyurethane foam with halogen-free fire safety additives. Intumescent foam close the hole during fire, preventing the spread of fire and smoke.

- fire resistance class up to EI 120
- mixed penetration seal
- to medium-sized and large fire protection penetration seals
- penetration seals with frequently changing pass-through installations
- for use in walls and floors

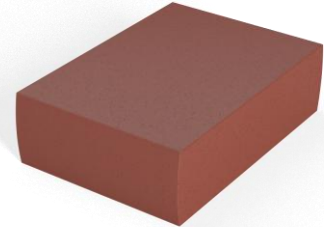

→ APPLICATION

The **INTU FR BRICK** intumescent fire stop brick is intended to be used as mixed penetration seal to temporarily or permanently reinstate the fire resistance performance of flexible wall, rigid wall and rigid floor construction where they have been provided, with apertures which are penetrated by various cables, waveguides, conduits / tubes, metal pipes, plastic pipes and cable support constructions (perforated or non-perforated steel cable trays and steel ladders).

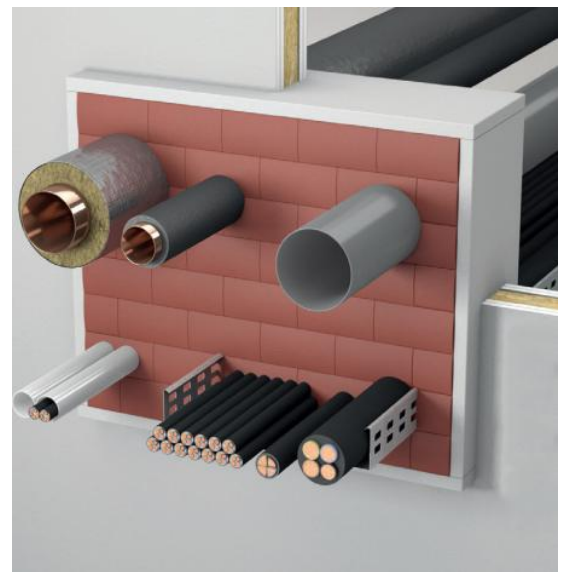

Flexible walls:

The wall must be minimum thickness 94 mm. Must have steel or timbers profile structure covered on both sides with minimum 2 layers of boards with minimum thickness 12,5 mm or minimum one layer of boards (minimum thickness 25 mm) with classification.

Rigid walls:

The wall must be minimum 100 mm thickness, made of concrete, reinforced concrete, concrete blocks, cellular concrete, ceramic brick (solid, hollow or lattice) or silicate brick (solid or hollow) with a density of min. 450 kg/m³.

Rigid floors:

The floor must be 150 mm minimum thickness. Must have concrete, aerated concrete, cellular concrete, reinforced concrete or masonry structure, with min. density $\rho \geq 450$ kg/m³.

→ COMPLIANCE

- Test standard:
EN 1366-3 / EAD 350454-00-1104
- European Technical Assessment:
ETA-10/0431 and ETA-11/0206
- Declaration of Performance:
ZZ230-20180701
- Certificate of Constancy of Performance
0761-CPR-0187

→ AVAILABILITY

Product	Type	Unit	Pallet (pcs)	Article number
INTU FR BRICK	200x144x60 mm	BOX (18pcs)	450 (25xBOX)	INFBRK

→ TRANSPORT AND STORAGE

Store in dry and cool conditions at temperatures between + 5°C and + 25°C.

INTU FR BRICK

Intumescent fire stop brick

TDS TECHNICAL DATA SHEET

→ INSTALLATION METHOD

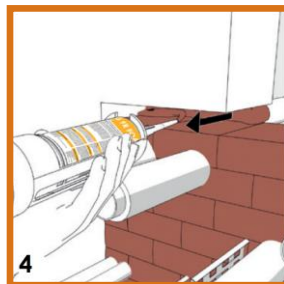
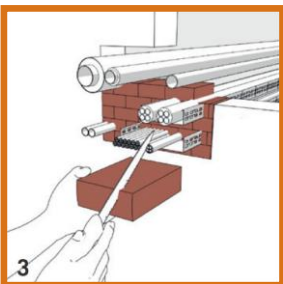
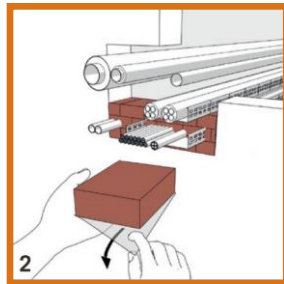
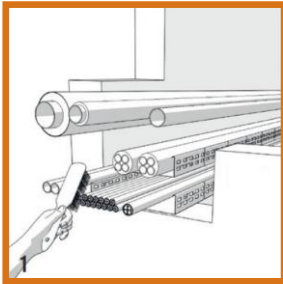

1. Clean the installations from dust, dirt and grease.
2. Remove the **INTU FR BRICK** protective foil. Place the blocks in layers (like in a brick bond in masonry, i.e. layer-by-layer offset of the vertical butt joints) so that they fit tightly in the component opening.
3. In the area of penetrating elements, cut the **INTU FR BRICK** to the required size.
4. Fill the remaining gaps with **INTU FR FOAM 2K** fire retardant foam. The filling depth must be equal to the minimum seal thickness. The maximum area that can be filled with **INTU FR FOAM 2K** is maximum 450 mm x 500 mm (width x height).

Gaps between cables should be filled with fire retardant mass, e.g. **INTU FR MASTIC**, 20 mm deep, from both sides. Joints between **INTU FR BRICK** blocks and between the edge of the opening and bricks do not require any additional sealing.

→ TECHNICAL DATA

Table 1 Properties of the **INTU FR BRICK** fire protection block

Colour	Red / brown
Shelf life	12 months in unopened packaging at a temperature between 5°C and 30°C
Transportation storage temp.	+5 °C to +30 °C (store dry and dustfree in the original packaging)
Application temperature	+15 °C to +30 °C (optimally +20 °C tot +25 °C)
Temperature resistance	-20 °C to +80 °C
Cuttability	Direct
VOC	< 2 µg/m³
Density	ρ = 240 kg/m³ - 300 kg/m³
Thermal conductivity (λ)	0,103 W/(m·K)
Expansion pressure	No expansion pressure measurable
Expansion factor ¹⁾	from 1.6 x to 4.5 x
Category of use ²⁾	Type Z ₁ in accordance with EAD 350454-00-1104
Possibility of coat	Yes
Air permeability	Q ₅₀ ≤ 0.82 m³/(h·m²) / Q ₆₀₀ = 6.61 m³/(h·m²) Q ₅₀ = 1.12 m³/(h·m²)/Q ₆₀₀ = 7.65 m³/(h·m²)
Acoustic properties	RW 45 dB (test dimension 350 x 350 x 144 mm) RW 49 dB (test dimension 360 x 360 x 200 mm)
Fire class	E in accordance with EN 13501-1
Approvals	ETA-10/0431 and ETA-11/0206
Function retention	10 years

Table 2 The opening size of fire penetration seal

Partition		Penetration seal parameters		
Class minutes		EI 60	EI 120	Height H [mm]
Type	Thick. [mm]	Width W [mm]		
		For seal thick. b=144mm	For seal thick. b=200mm	
Rigid wall	b ≥ 100	600		1000
		1000		600
Partition		Penetration seal parameters		
Rigid floor	b ≥ 150	unlimited	unlimited	≤ 375
		6000	unlimited	400
		2250	4800	450
		1000	1300	600
		---	1000	700
Partition		Penetration seal parameters		
Flexible wall	b ≥ 94	600		1000
		1000		600

→ FIRE RESISTANCE CLASSIFICATION

Penetrating element		Fire classification for walls and floors	
CABLES	Diameter Ø (mm)	Depth of foam injection b ≥ 144 mm	Depth of foam injection b ≥ 200 mm
Sheathed electrical/ telecommunication/ optical fibre cables	Ø ≤ 21	EI 60 / E 60	EI 90 / EI 120 ¹⁾ / E 120
	21 < Ø ≤ 50	EI 60 / E 60	wall: EI 90 / EI 120 ¹⁾ / E 120 floor: EI 120 ¹⁾ / E 120
	50 < Ø ≤ 80	EI 60 / E 60	EI 120 ¹⁾ / E 120
Tied bundles up to 100 mm overall diameter containing sheathed electrical/ telecommunication/ optical fibre cables	Ø _{BUNDLE} ≤ 100 Ø _{CABLE} ≤ 21	EI 60 / E 60	EI 90 / EI 120 ¹⁾ / E 120
Non-sheathed cables	Ø ≤ 24	wall: EI 45 / E 60 floor: EI 60 / E 60	EI 60 / E 120
Steel conduits / tubes with / without cables	Ø ≤ 16	EI 60 – C/U	EI 120 – U/C
Plastic conduits and bundles consisting of plastic conduits with / without cables	Ø _{BUNDLE} ≤ 80 Ø _{CONDUIT} ≤ 63	EI 60 – U/C	EI 120 – U/C
	Ø _{BUNDLE} ≤ 100 Ø _{CONDUIT} ≤ 63	EI 60 – U/C	EI 90 – U/C
Speedo [®] pipe and bundles consisting of speedo [®] pipe with / without optical fibre cables	Ø _{BUNDLE} ≤ 80 Ø _{PIPE} ≤ 12	EI 60 – U/C	wall: EI 120 – U/C floor: EI 90 – U/C
Waveguides	CELLFLEX [®] :	Ø ≤ 59,9 mm	EI 120 – U/C
	CELLFLEX [®] Lite:	Ø ≤ 50,2 mm	
	RADIAFLEX [®] :	Ø ≤ 48,2 mm	
	HELIAX [®] :	Ø ≤ 51,1 mm	
	RADIAX [®] :	Ø ≤ 49,8 mm	

¹⁾ To obtain selected fire resistance class you need wrap the installation with **INTU FR BANDAGE** on both sides of the wall or both sides of the floor

Penetrating element			Fire classification for walls and floors	
NON-INSULATED METAL PIPES	Diameter Ø (mm)	Pipe wall thickness	Depth of foam injection b ≥ 144 mm	Depth of foam injection b ≥ 200 mm
Copper pipes	Ø ≤ 18 mm	≥ 1,0 mm	EI 60 – C/U	EI 60 – C/U
Steel pipes	Ø ≤ 35 mm	≥ 1,0 mm	EI 60 – C/U	EI 90 – C/U

Penetrating element			Fire classification for walls and floors	
PLASTIC PIPES	Diameter Ø (mm)	Pipe wall thickness	Depth of foam injection b ≥ 144 mm	Depth of foam injection b ≥ 200 mm
Plastic pipes	Ø ≤ 50 mm	1,8 – 5,6 mm	EI 60 – U/C	EI 120 – U/C

INTU FR BRICK

Intumescent fire stop brick

TDS TECHNICAL DATA SHEET

Type of penetrating element					Fire resistance classification	
PRE-INSULATED METAL PIPES			Insulation type	Insulation thickness (mm)	Additional product: INTU FR BANDAGE	Foam injection depth b ≥ 200 mm
Type of pipe	Outer diameter of pipe (mm)	Pipe wall				
WICU®Eco	12,0	1,0	PUR	11,0	wrap the installation with INTU FR BANDAGE on both sides of the wall or only top side of the floor	EI 90 – C/U
	15,0			11,5		
	18,0			12,0		
	22,0			12,5		
	28,0	1,5		17,5		
	35,0			18,0		
	42,0			24,0		
	54,0			27,5		
WICU®Flex	12,0; 15,0; 18,0; 22,0	1,0	PE	6,0	wrap the installation with INTU FR BANDAGE on both sides of the wall or only top side of the floor	EI 90 / E 120 – C/U
WICU®Frio	6,0	1,0	PE	8,0		
	10,0; 12,0; 15,0; 18,0; 22,0			10,0		
WICU®Clim	6,35	0,762	PE	6,0	EI 120 – C/U	
	9,52	0,813		8,0		
	12,70	0,813		10,0		
	15,87	0,889				
	19,05	0,889				
22,22	0,889					
Tubolit® Split /Tubolit® DuoSplit	6,35; 9,52; 12,70	0,8	PE	9,0	-	EI 120– C/U
	15,88; 19,05; 22,22	1,0				

Table 3 Minimum working clearance depending on penetrating element

Minimum working clearance (measured from the surface of the pipe)				
Penetrating element	a1	a2	a3	
Cables/Waveguides/Cable trays/Conduits (incl. speed pipe®)	50 mm	0 mm	<ul style="list-style-type: none"> Cables/Waveguides/Cable trays/Conduits Cable trays (vertical) Non-insulated metal pipes Other penetrating elements 	0 mm 50 mm 60 mm 50 mm
Mineral wool	0 mm	0 mm	<ul style="list-style-type: none"> Mineral wool insulated metal pipes Plastic pipes with pipe collar Non-insulated metal pipes Other penetrating elements 	0 mm 0 mm 60 mm 50 mm
Foamglas®-PSH insulated metal pipes	0 mm	0 mm	<ul style="list-style-type: none"> Foamglas®-PSH insulated metal pipes Non-insulated metal pipes Other penetrating elements 	0 mm 60 mm 50 mm
AF/Armaflex insulated metal pipes	35 mm	35 mm	<ul style="list-style-type: none"> AF/Armaflex (thickness > 9 mm) insulated metal pipes AF/Armaflex (thickness = 9 mm) insulated metal pipes Non-insulated metal pipes Other penetrating elements 	35 mm 50 mm 60 mm 50 mm
Non-insulated metal pipes	35 mm	35 mm	<ul style="list-style-type: none"> Non-insulated metal pipes Other penetrating elements 	60 mm 60 mm
Pre-insulated metal pipes	0 mm	0 mm	<ul style="list-style-type: none"> Pre-insulated metal pipes Non-insulated metal pipes Other penetrating elements 	0 mm 60 mm 50 mm
Plastic pipes (without pipe collar)	50 mm	50 mm	<ul style="list-style-type: none"> Plastic pipes (without pipe collar) Non-insulated metal pipes Other penetrating elements 	50 mm 60 mm 50 mm
Plastic pipes (with pipe collar)	50 mm*	50 mm*	<ul style="list-style-type: none"> Plastic pipes (with pipe collar) Mineral wool insulated metal pipes Non-insulated metal pipes Other penetrating elements 	0 mm 0 mm 60 mm 50 mm

INTU FR BRICK

Intumescent fire stop brick

TDS TECHNICAL DATA SHEET

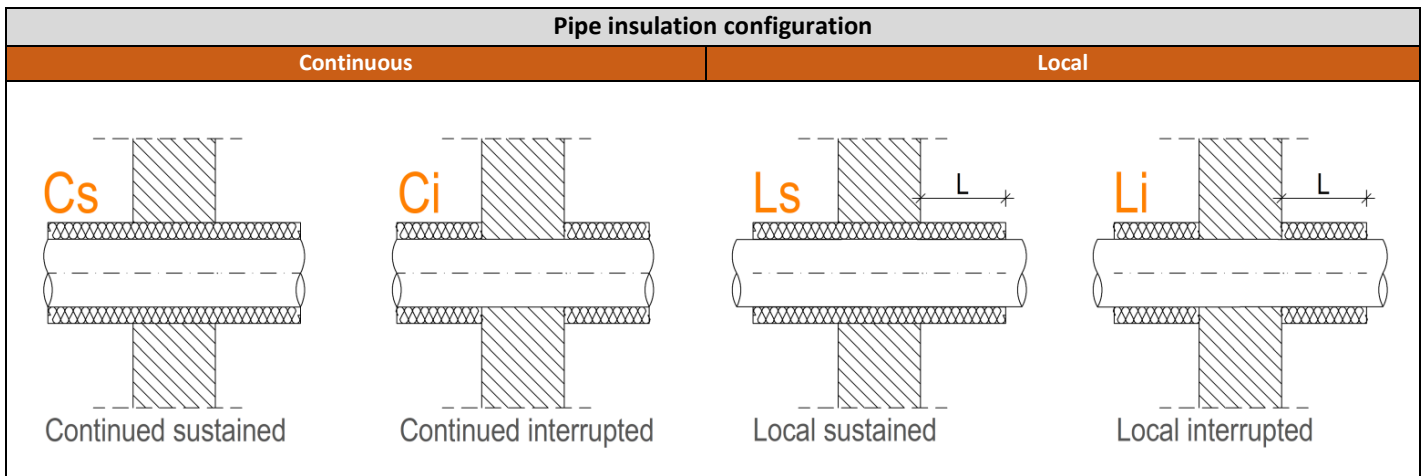

Type of penetrating element				Fire resistance classification		
MINERAL WOOL INSULATED METAL PIPES Density of mineral wool $\rho \geq 90 \text{ kg / m}^3$		Pipe wall thickness (mm)	Insulation* length (mm)	Insulation thickness [mm]	Foam inj. depth $b \geq 144 \text{ mm}$	Foam injection depth $b \geq 200 \text{ mm}$
Metal pipes with mineral wool insulation	$\varnothing \leq 35,0 \text{ mm}$	1,0 – 14,2	(insulation configuration: Ls, Cs, Li, Ci) $L \geq 428$	≥ 30	EI 60 – C/U	wall: EI 90 – C/U; E 120 – C/U floor: EI 120 – C/U
	$\varnothing \leq 54,0 \text{ mm}$			≥ 30		
	$\varnothing \leq 88,9 \text{ mm}$		$(Ls, Cs, Li, Ci) \geq 528$			
Metal pipes with mineral wool insulation	$\varnothing \leq 168,3 \text{ mm}$		$(Ls, Cs, Li, Ci) \geq 596$	≥ 50		wall: EI 120 – C/U floor: EI 90 – C/U
AF/Armaflex INSULATED METAL PIPES		Pipe wall thickness (mm)	Insulation length (mm)	Insulation thickness [mm]	Foam inj. depth $b \geq 144 \text{ mm}$	Foam injection depth $b \geq 200 \text{ mm}$
Metal pipes with AF/Armaflex insulation	$\varnothing \leq 35,0 \text{ mm}$	1,0 – 14,2	(insulation config. Ls, Cs): ≥ 500	9,0 – 35,0	EI 60 – C/U	EI 90 – C/U
	$\varnothing \leq 42,0 \text{ mm}$	1,5 – 14,2		9,0 – 36,5		
	$\varnothing \leq 54,0 \text{ mm}$	2,0 – 14,2		9,0 – 38,0		
	$\varnothing \leq 88,9 \text{ mm}$			41,5		
Foamglas® - PSH		Pipe wall thickness (mm)	Insulation length (mm)	Insulation thickness [mm]	Foam inj. depth $b \geq 144 \text{ mm}$	Foam injection depth $b \geq 200 \text{ mm}$
Foamglas® - PSH insulated metal pipes	$\varnothing \leq 28,0 \text{ mm}$	1,0 – 14,2	(insulation config. Ls, Cs) ≥ 500	25,0 – 50,0	-	EI 120 – C/U
	$\varnothing \leq 54,0 \text{ mm}$			25,0 – 50,0		wall: EI 90 – C/U; E 120 – C/U floor: EI 120 – C/U
				50,0		EI 120 – C/U
	$\varnothing \leq 88,9 \text{ mm}$			40,0		wall: EI 120 – C/U floor: EI 90 – C/U; E 120 – C/U

INTU FR BRICK

Intumescent fire stop brick

TDS TECHNICAL DATA SHEET

➔ SOLUTION DETAILS

FLEXIBLE WALLS with thickness $c \geq 94$ mm

Fig. 1 Cable penetration seal in a flexible wall - detail with increased wall thickness

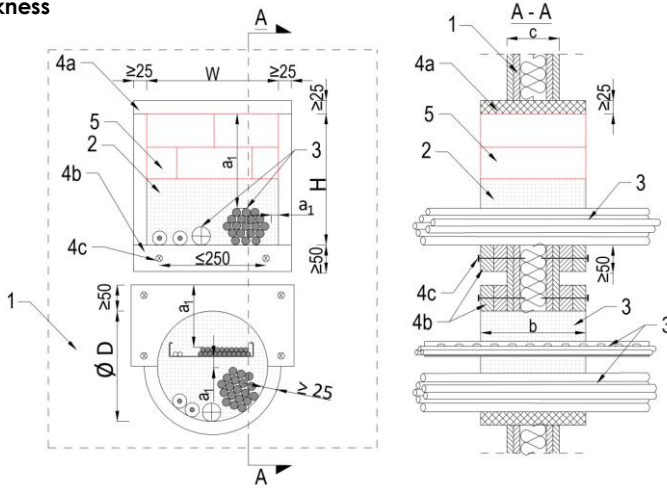

1. Flexible wall, $c \geq 94$ mm
2. Filling with **INTU FR FOAM 2K**
* **INTU FR FOAM 2K** and **INTU FR BRICK** can be used interchangeably
3. Cable / cable bundles / cables in trays / mixed penetration seals
- 4a. Facing made of two layers of gypsum board (min. thickness 2×12.5 mm) or silicate board (min. thickness 25 mm)
- 4b. Increasing the wall thickness on one / both sides to at least the min. thickness of the penetration seal (installation of the board around the opening, board width ≥ 50 mm)
- 4c. Fixing with screws to plaster/ silicate boards
5. Filling with **INTU FR BRICK**

Minimum mounting distance:
 $a_1 \geq 0$ mm

RIGID WALLS with thickness $c \geq 100$ mm

Fig.2 Cable penetration seal in rigid wall

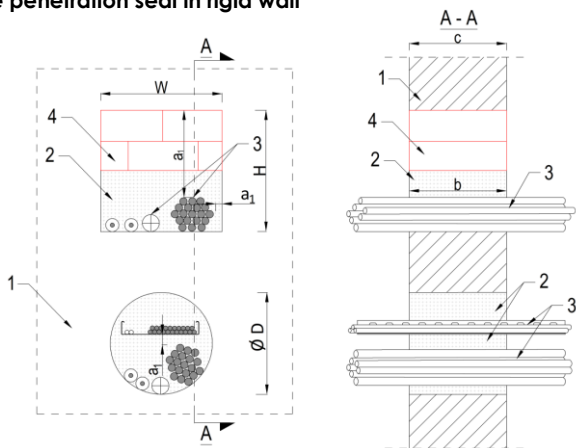

1. Rigid wall with thickness $c \geq 100$ mm
2. Filling with **INTU FR FOAM 2K**
* **INTU FR FOAM 2K** and **INTU FR BRICK** can be used interchangeably
3. Cable / cable bundles / cables in trays / mixed penetration seals
4. Filling with **INTU FR BRICK**

Minimum mounting distance:
 $a_1 \geq 0$ mm

Fig.3 Mixed penetration seal in rigid wall

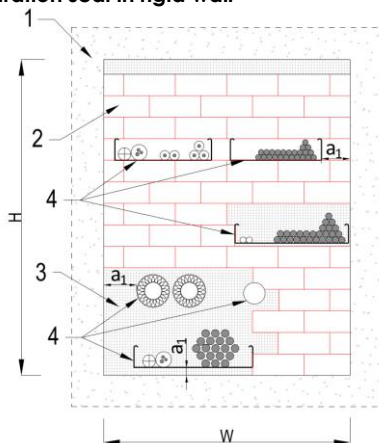

1. Rigid wall with thickness $c \geq 100$ mm
2. Filling with **INTU FR BRICK**
3. Filling with **INTU FR FOAM 2K**
* **INTU FR FOAM 2K** and **INTU FR BRICK** can be used interchangeably
4. Cable / cable bundles / cables in trays / mixed penetration seals

Minimum mounting distance:
 $a_1 \geq 0$ mm

INTU FR BRICK

Intumescent fire stop brick

TDS TECHNICAL DATA SHEET

RIGID FLOOR with thickness $c \geq 150$ mm

Fig.4 Cable penetration seal in floor - detail with increased floor thickness

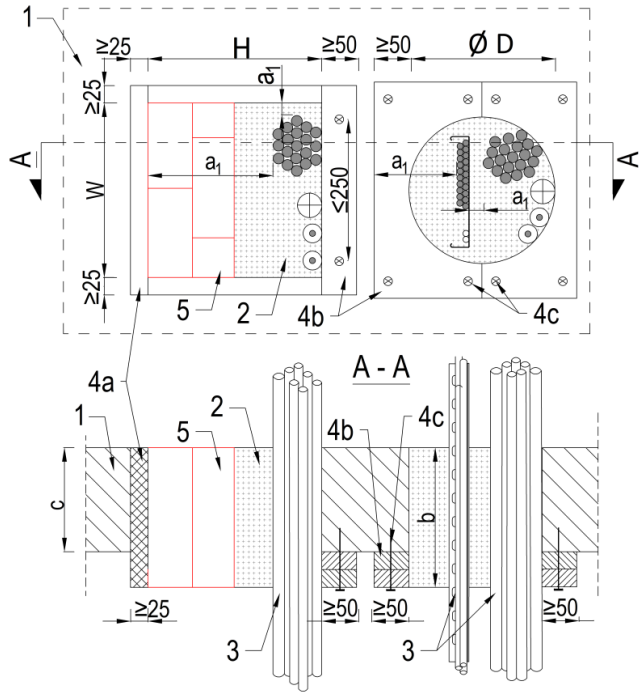

1. Rigid floor with thickness $c \geq 100$ mm
2. Filling with **INTU FR FOAM 2K**
* **INTU FR FOAM 2K** and **INTU FR BRICK** can be used interchangeably
3. Cable / cable bundles / cables in trays / mixed penetration seals
- 4a. Facing made of two layers of gypsum board (min. thickness 2×12.5 mm) or silicate board (min. thickness 25 mm)
- 4b. Increasing the wall thickness on one / both sides to at least the min. thickness of the penetration seal (installation of the board around the opening, board width ≥ 50 mm)
- 4c. Fixing with screws to plaster/ silicate boards
5. Filling with **INTU FR BRICK**

Minimum mounting distance:
 $a_1 \geq 0$ mm

Fig.5 Cable penetration seal in floor

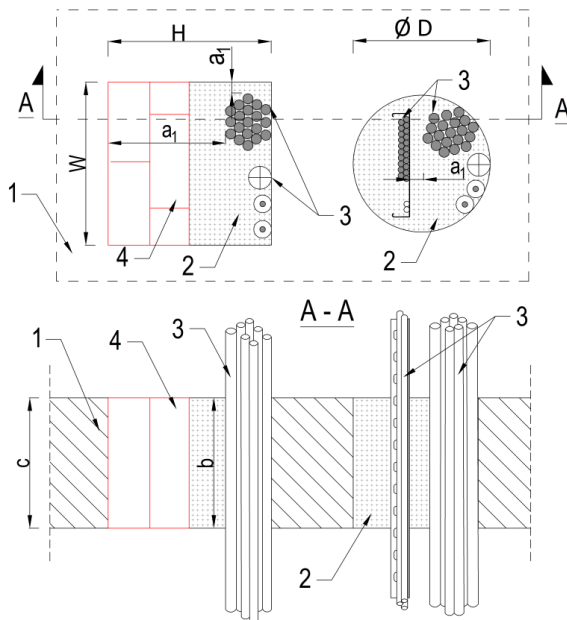

1. Rigid floor with thickness $c \geq 100$ mm
2. Filling with **INTU FR FOAM 2K**
* **INTU FR FOAM 2K** and **INTU FR BRICK** can be used interchangeably
3. Cable / cable bundles / cables in trays / mixed penetration
4. Filling with **INTU FR BRICK**

Minimum mounting distance:
 $a_1 \geq 0$ mm

INTU FR BRICK

Intumescent fire stop brick

TDS TECHNICAL DATA SHEET

Example of use INTU FR BRICK in penetration seal

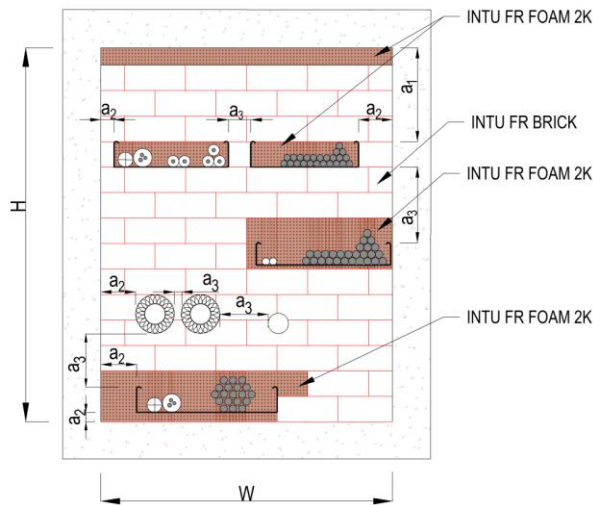

Minimum working clearances in accordance with Table 3

a₁-penetrating element / top edge of penetration seal

a₂-penetrating element /side or lower edge of penetration seal

a₃-penetrating element / penetrating element

Support for penetrations through Rigid Floors ≥ 150 mm

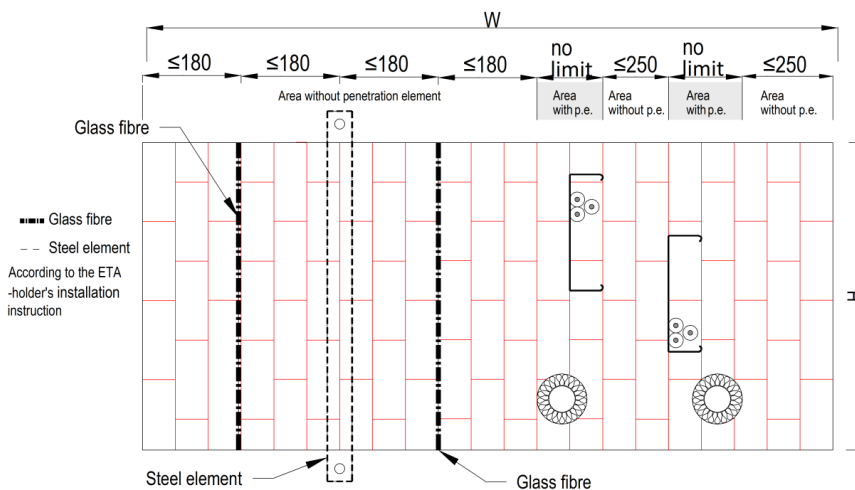

Top view:
Installation of glass fabric or steel element **for b = 144 mm**

In case of installation in floor openings free areas (without any elements penetrating the penetration seal) have to be supported with steel element (minimum width of 40 mm and minimum thickness of 2 mm) on the bottom side of the floor. Alternatively it is possible to install a glass fabric according to the ETA-holder's installation instruction every 180 mm between INTU FR BRICK (width of glass fabric \geq b).

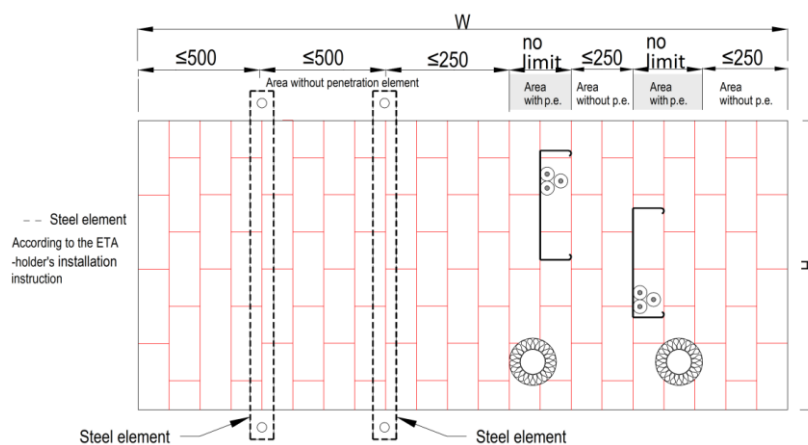

Top view:
Installation of steel elements **for b = 200 mm**

In case of installation in floor openings free areas (without any elements penetrating the penetration seal) have to be supported with steel element (minimum width of 40 mm and minimum thickness of 2 mm) on the bottom side of the floor. Alternatively it is possible to install a glass fabric according to the ETA-holder's installation instruction every 180 mm between INTU FR BRICK (width of glass fabric \geq b).