

INTU FR FOAM 2K

Fire protection foam

TDS TECHNICAL DATA SHEET



CE

EOTA

INTU FR FOAM 2K

Fire protection foam

TDS TECHNICAL DATA SHEET

➔ PRODUCT DESCRIPTION

The **INTU FR FOAM 2K** intumescent fire-retardant foam based on polyurethane. After application, it reacts and increases its volume. During a fire, it swells, preventing the spread of fire, creating a barrier ensuring that the partition remains tight and insulating up to EI 120.

➔ APPLICATION

The **INTU FR FOAM 2K** intumescent fire protection foam is cartridges on the basis of polyurethane. Is intended to be easy used as mixed penetration seal to the fire resistance performance of flexible wall, rigid wall and rigid floor construction where they have been provided, with apertures which are penetrated by various cables, waveguides, conduits / tubes, metal pipes, plastic pipes and cable support constructions (perforated or non-perforated steel cable trays and steel ladders).



Flexible walls:	The wall must be minimum thickness 94 mm. Must have steel or timbers profile structure covered on both sides with minimum 2 layers of boards with minimum thickness 12,5 mm or minimum one layer of boards (minimum thickness 25 mm) with classification.
Rigid walls:	The wall must be minimum 100 mm thickness, made of concrete, reinforced concrete, concrete blocks, cellular concrete, ceramic brick (solid, hollow or lattice) or silicate brick (solid or hollow) with a density of min. 450 kg/m ³ .
Rigid floors:	The floor must be 150 mm minimum thickness. Must have concrete, aerated concrete, cellular concrete, reinforced concrete or masonry structure, with min. density $\rho \geq 450$ kg/m ³ .

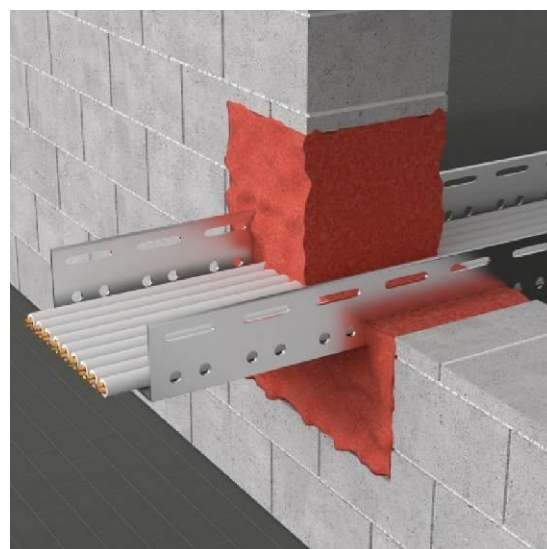

➔ AVAILABILITY

Product	Unit	Pallet (pcs)	Article number
INTU FR FOAM 2K 380 ml	BOX (6 pcs)	360 (60xBOX)	INFO2K380
Additional equipment	Unit	Pallet (pcs)	Article number
INTU FR FOAM 2K HandyMax	pcs	N/A	INFO2KHM
INTU FR FOAM 2K PowerMax	pcs	N/A	INFO2KHMPM
INTU FR FOAM 2K MIXING NOZZLE	BOX (50 pcs)	N/A	INF2KMIX

➔ COMPLIANCE

- Test standard:
EN 1366-3 / EAD 350454-00-1104
- European Technical Assessment:
ETA-10/0431 and ETA-11/0206
- Declaration of Performance:
ZZ330-20220401
- Certificate of Constasy of Performance
0761-CPR-0208

➔ TRANSPORT AND STORAGE

Store in dry and cool conditions at temperatures between + 5°C and + 30°C.

INTU FR FOAM 2K

Fire protection foam

TDS TECHNICAL DATA SHEET

→ INSTALLATION METHOD

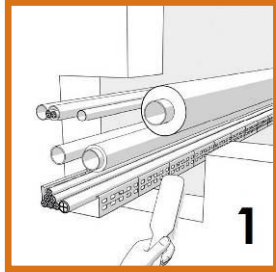

1. Clean the installations from dust, dirt and grease.



2. Hold the cartridge vertically with the tip pointing upward, unscrew the cap and firmly screw on the provided mixing nozzle.

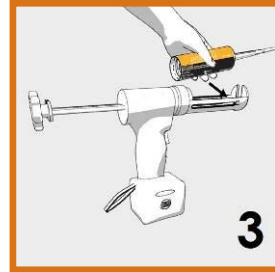

3. Insert the cartridge into the intended dispensing gun.

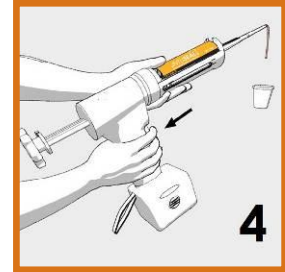

4. Start pressing out and discard non-uniform initial material.

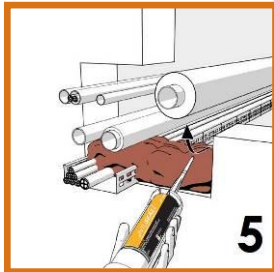

5. Fill the opening from back to front. In this process build up the foam from bottom to top, always guide the tip of the mixing nozzle above the foam so that the material does not stick or clog. After a work interruption longer than approximately 50 seconds the foam hardens in the mixing nozzle, which then must be replaced. Prior to changing the mixing nozzle, offload the dispensing gun, and carefully replace the mixing nozzle.

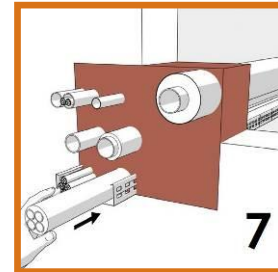
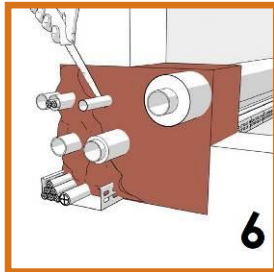

6. After approx. 2 minutes projecting foam residues can be cut off with a suitable knife in compliance with the necessary protective measures and safety regulations.

7. Cables that will be installed retroactively can be routed through the existing foam.

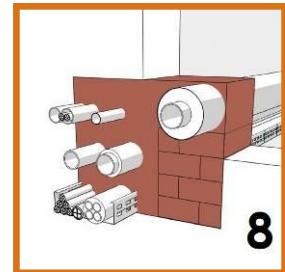

8. The fire protection penetration seal is finished. Complete any important information on the penetration seal label.

Note: If the mixing nozzle is clogged, never use force to press out the material: force can destroy the cartridge or the dispensing gun! Wear suitable protective gloves and protective clothing for the work.

Additional equipment	
INTU FR FOAM 2K HandyMax	INTU FR FOAM 2K PowerMax
<p>Manual injection dispenser. The dispenser is made of high-quality materials that guarantee long and trouble-free operation. The special design of the dispensers ensures perfect matching of compatible containers.</p>	<p>Electrical injection dispenser. The dispenser has included: trigger drive module with regulator, 7.2 V lithium-ion battery, speed control, LED light. Max speed: 4 mm/sec. Max power: 600 kgf / 6000 N / 1,320 lbs.</p>

INTU FR FOAM 2K

Fire protection foam

TDS TECHNICAL DATA SHEET

➔ TECHNICAL DATA

Table 1 Properties of the **INTU FR FOAM 2K** intumescent fire protection foam

Colour	Red / brown*
Shelf life	12 months in unopened packaging at a temperature between 5°C and 30°C
Transportation storage temp.	+5 °C to +30 °C (store dry and dustfree in the original packaging)
Application temperature	+15 °C to +30 °C (optimally +20 °C tot +25 °C)
Temp. resistance	-20 °C to +80 °C
Foam yield*	Up to 2.1 litres (at 22 °C material and ambient temperature)
Work interruption*	Approx. 50 sec
Cuttability	After approx. 90 seconds (at 22 °C material and ambient temperature)
VOC	< 2 µg/m³
Density	$\rho = 215 \text{ kg/m}^3$
Thermal cond. (λ)	0,088 W/(m*K)
Exp. pressure	No expansion pressure measurable
Expansion factor ¹⁾	from 1.6 x to 4.5 x
Category of use ²⁾	Type Z ₁ in accordance with EAD 350454-00-1104
Recoatable ³⁾	Yes
Air permeability	$Q_{600} \leq 0.08 \text{ m}^3/(\text{h} \cdot \text{m}^2)$ Test standard EN 1026
Resistance to static pressure differences	No visible changes up to the maximum test pressure of the test device (P _{max} =10000 Pa).
Acoustic properties	RW 66 dB (test dimension 360 x 360 x 200 mm)
Fire class	E in accordance with EN 13501-1
Approvals	ETA-10/0431 and ETA-11/0206
Function retention	10 years

* Foam output and max. possible work interruptions depend on the material and ambient temperature.

¹⁾ Expansion factor. Tested on samples at 450 °C for 25 minutes without overload. The expansion factor is a laboratory characteristic value. The expansion factor in an installed state depends on the existing preconditions.

²⁾ Permissible environmental conditions. Conduit seal for use in conditions with $\geq 85\%$ RH, protected from temp. below 0 °C, and without exposure to rain and/or UV.

³⁾ Influence of finishing materials and chemicals the following paints and occasional brief influences from chemicals will not change the fire protection properties: Coating materials : Dispersion paint, alkyd paint, polyurethane acrylic paint, epoxy resin paint, silicone Solvent/oil : Butyl acetate, butanol, trichloroethylene, xylene, acetone, turpentine Gaseous chemicals : Brief storage with concentrated ammonium hydroxide solution

Environmental conditions with high humidity levels and/or some coating materials and chemicals may change the color or limit color changes.

Table 2 The maximum gap dimensions based on EN 13501-2 for multiple and single penetrations

Partition construction	Mixed penetrations (cable trays, cables, tubes and pipes)	Cable penetrations (cable and cable ducts)
	Maximum gap WxH [mm]	Maximum gap WxH [mm]
Solid walls: aerated concrete, concrete, reinforced concrete or masonry	450 x 500	270 x 270 or Ø300
Lightweight partitions: wooden or steel construction with cladding on both sides	450 x 500	270 x 270 or Ø300
Solid floors: aerated concrete, concrete or reinforced concrete	450 x 450	270 x 270 or Ø300

INTU FR FOAM 2K

Fire protection foam

TDS TECHNICAL DATA SHEET

➔ FIRE RESISTANCE CLASSIFICATION for cable penetration seals (opening size 270 mm x 270 mm or Ø300 mm)

Penetrating element		Fire classification			
		Depth of foam injection b			
		b ≥ 100 mm		b ≥ 144 mm	
CABLES	Diameter Ø (mm)	Wall	Floor	Wall	Floor
Sheathed electrical/ telecommunication/ optical fibre cables	Ø ≤ 21	EI 60 / E 120		EI 120	EI 90/ E 120
	21 < Ø ≤ 50	EI 45 /EI 60 ⁽¹⁾ / E 120	-	EI 60 / E 120	
	50 < Ø ≤ 80	-			
Tied bundles up to 100 mm overall diameter containing sheathed electrical/ telecommunication/ optical fibre cables	Ø _{BUNDLE} ≤ 100 Ø _{CABLE} ≤ 21				
Steel conduits / tubes with / without cables	Ø ≤ 16	-		EI 60 – U/C / E 120 – U/C	
Plastic conduits with / without cables	Ø ≤ 16			EI 120 – U/C	
Plastic conduits and bundles consisting of plastic conduits with / without cables	Ø _{BUNDLE} ≤ 80 Ø _{CONDUIT} ≤ 40 Ø _{BUNDLE} ≤ 100 Ø _{CONDUIT} ≤ 63				
Speed•pipe® and bundles consisting of speed•pipe® with / without optical fibre cables	Ø _{BUNDLE} ≤ 80 Ø _{PIPE} ≤ 12	EI 120 – U/C		EI 90 – U/C	

⁽¹⁾ To obtain selected fire resistance class you need use **INTU FR FOAM** around the installation on both sides, minimum dimensions of 30 mm x 20 mm (length x thickness)

Penetrating element		Fire classification			
		Depth of foam injection b			
		b ≥ 200 mm		b ≥ 250 mm	
CABLES	Diameter Ø (mm)	Wall	Floor	Wall	Floor
Sheathed electrical/ telecommunication/ optical fibre cables	Ø ≤ 21	EI 120		EI 120	
	21 < Ø ≤ 50	EI 90 / EI 120 ⁽²⁾ / E 120			
	50 < Ø ≤ 80			EI 90 / E 120	
Tied bundles up to 100 mm overall diameter containing sheathed electrical/	Ø _{BUNDLE} ≤ 100 Ø _{CABLE} ≤ 21	EI 90 / E 120	EI 90/ EI 120 ⁽²⁾ / E 120	EI 90 / E 120	EI 120
Steel conduits / tubes with / without cables	Ø ≤ 16	EI 120 – U/U	EI 90 – U/U E 120 – U/U	EI 120 – U/U	

⁽²⁾ To obtain selected fire resistance class you need wrap the installation with **INTU FR BANDAGE** on both sides of the wall or floor

INTU FR FOAM 2K

Fire protection foam

TDS TECHNICAL DATA SHEET

➔ FIRE RESISTANCE CLASSIFICATION for mixed penetration seals

Type of penetrating element			Fire resistance classification	
CABLES			Foam injection depth b ≥ 144	Foam injection depth b ≥ 200 mm
Sheathed electrical/ telecommunication/ optical fiber cables up to a max. outer diameter	Ø ≤ 21 mm		EI 60	EI 90 / EI 120 ⁽²⁾
	Ø ≤ 50 mm		EI 60	wall: EI 90 / EI 120 ⁽²⁾ floor: EI 90 / EI 120 ⁽²⁾
	Ø ≤ 80 mm		EI 60	EI 120 ⁽²⁾ / E 120
Tied bundles containing sheathed electrical / telecommunication / optical fibre cables up to a max. outer diameter	Ø _{BUNDLE} ≤ 100 mm Ø _{CABLE} ≤ 21 mm		EI 60	EI 90 / EI 120 ⁽²⁾
Non-sheathed cables up to a max. outer diameter	Ø _{CABLE} ≤ 24 mm		wall: EI 45 / E60 floor: EI 60	EI 60 / E 120
Waveguides	CELLFLEX@:	Ø ≤ 59,9 mm	-	EI 120 – U/C
	CELLFLEX@ Lite:	Ø ≤ 50,2 mm		
	RADIAFLEX@:	Ø ≤ 48,2 mm		
	HELIAX@:	Ø ≤ 51,1 mm		
	RADIAX@:	Ø ≤ 49,8 mm		

⁽²⁾ The **INTU FR BANDAGE** must be applied on both surfaces of wall or floor

Type of penetrating element					Fire resistance	
PRE-INSULATED METAL PIPES			Insulation type	Insulation thickness (mm)	Additional product: INTU FR BANDAGE	Foam injection depth b ≥ 200 mm
Type of pipe	Outer diameter of pipe (mm)	Pipe wall				
WICU@Eco	12,0	1,0	PUR	11,0	Wall: one layer on both sides of the penetration seal (length* ≥ 150 mm, nominal thickness 3 mm) Floor: one layer on the top side of the penetration seal	EI 90 – C/U
	15,0			11,5		
	18,0			12,0		
	22,0			12,5		
	28,0	1,5		17,5		
	35,0			18,0		
	42,0			24,0		
	54,0			27,5		
WICU@Flex	12,0; 15,0; 18,0; 22,0	1,0	PE	6,0	Floor: one layer on the top side of the penetration seal (length* ≥ 150 mm, nom. thickness 3 mm)	wall: EI 90 – C/U; E 120 – C/U floor: EI 90 – C/U; E 120 – C/U
WICU@Frio	6,0	1,0	PE	8,0		EI 120 – C/U
	10,0; 12,0; 15,0; 18,0; 22,0			10,0		
WICU@Clim	6,35	0,762	PE	6,0		
	9,52	0,813		8,0		
	12,70	0,813		10,0		
	15,87	0,889				
	19,05	0,889				
22,22	0,889					
Tubolit@ Split /Tubolit@ DuoSplit	6,35; 9,52; 12,70	0,8	PE	9,0	-	EI 120– C/U
	15,88; 19,05; 22,22	1,0				

*Measured from the surface of the penetration seal

INTU FR FOAM 2K

Fire protection foam

TDS TECHNICAL DATA SHEET

Type of penetrating element		Fire resistance classification		
CONDUITS / TUBES		Pipe wall thickness	Foam injection depth b ≥ 144 mm	Foam injection depth b ≥ 200 mm
Steel conduits tubes up to a max. outer diameter (with / without cables)	∅ ≤ 16 mm	≥ 1,5 mm	Ei 60 – U/C	wall: Ei 90 – U/C; E120 – U/C floor: Ei 90 – U/C
Plastic conduits with / without cables	∅ ≤ 63 mm	1,0 – 3,0 mm		Ei 120 – U/C
Bundles consisting of plastic conduits with / without cables ∅ _{PIPE} ≤ 63 mm	∅ _{BUNDLE} ≤ 80 mm			0,75 – 2,0 mm
	∅ _{BUNDLE} ≤ 100 mm	wall: Ei 90 – U/C; E 120 – U/C floor: Ei 90 – U/C		
Speed•pipe®	∅ ≤ 12 mm			
Bundles consisting of speed•pipe® with / without optical fibre cables	∅ _{BUNDLE} ≤ 80 mm ∅ _{PIPE} ≤ 12 mm			
NON-INSULATED METAL PIPES		Pipe wall thickness	Foam injection depth b ≥ 144 mm	Foam injection depth b ≥ 200 mm
Copper pipes	∅ ≤ 18 mm	1,0 – 14,2 mm	Ei 60 – C/U	Ei 60 – C/U E 120 – C/U
Steel pipes	∅ ≤ 35 mm	1,0 – 14,2 mm		wall: Ei 90 – C/U; E 120 – C/U floor: Ei 90 – C/U
PLASTIC PIPES / TUBES		Pipe wall thickness	Foam injection depth b ≥ 144 mm	Foam injection depth b ≥ 200 mm
Plastic pipes	∅ ≤ 50 mm	1,8 – 5,6 mm	Ei 60 – U/C	Ei 120 – U/C

Table 3 Minimum working clearance depending on penetrating element

Minimum working clearance				
Penetrating element	a ₁	a ₂	a ₃	
Cables/Waveguides/Cable trays/Conduits (incl. speed•pipe®)	50 mm	0 mm	<ul style="list-style-type: none"> Cables/Waveguides/Cable trays/Conduits Cable trays (vertical) Non-insulated metal pipes Other penetrating elements 	0 mm 50 mm 60 mm 50 mm
Mineral wool	0 mm	0 mm	<ul style="list-style-type: none"> Mineral wool insulated metal pipes Plastic pipes with pipe collar Non-insulated metal pipes Other penetrating elements 	0 mm 0 mm 60 mm 50 mm
Foamglas®-PSH insulated metal pipes	0 mm	0 mm	<ul style="list-style-type: none"> Foamglas®-PSH insulated metal pipes Non-insulated metal pipes Other penetrating elements 	0 mm 60 mm 50 mm
AF/Armaflex insulated metal pipes	35 mm	35 mm	<ul style="list-style-type: none"> AF/Armaflex (thickness > 9 mm) insulated metal pipes AF/Armaflex (thickness = 9 mm) insulated metal pipes Non-insulated metal pipes Other penetrating elements 	35 mm 50 mm 60 mm 50 mm
Non-insulated metal pipes	35 mm	35 mm	<ul style="list-style-type: none"> Non-insulated metal pipes Other penetrating elements 	60 mm 60 mm
Pre-insulated metal pipes	0 mm	0 mm	<ul style="list-style-type: none"> Pre-insulated metal pipes Non-insulated metal pipes Other penetrating elements 	0 mm 60 mm 50 mm
Plastic pipes (without pipe collar)	50 mm	50 mm	<ul style="list-style-type: none"> Plastic pipes (without pipe collar) Non-insulated metal pipes Other penetrating elements 	50 mm 60 mm 50 mm
Plastic pipes (with pipe collar)	50 mm*	50 mm*	<ul style="list-style-type: none"> Plastic pipes (with pipe collar) Mineral wool insulated metal pipes Non-insulated metal pipes Other penetrating elements 	0 mm 0 mm 60 mm 50 mm

*Measured from the surface of the pipe

INTU FR FOAM 2K

Fire protection foam

TDS TECHNICAL DATA SHEET

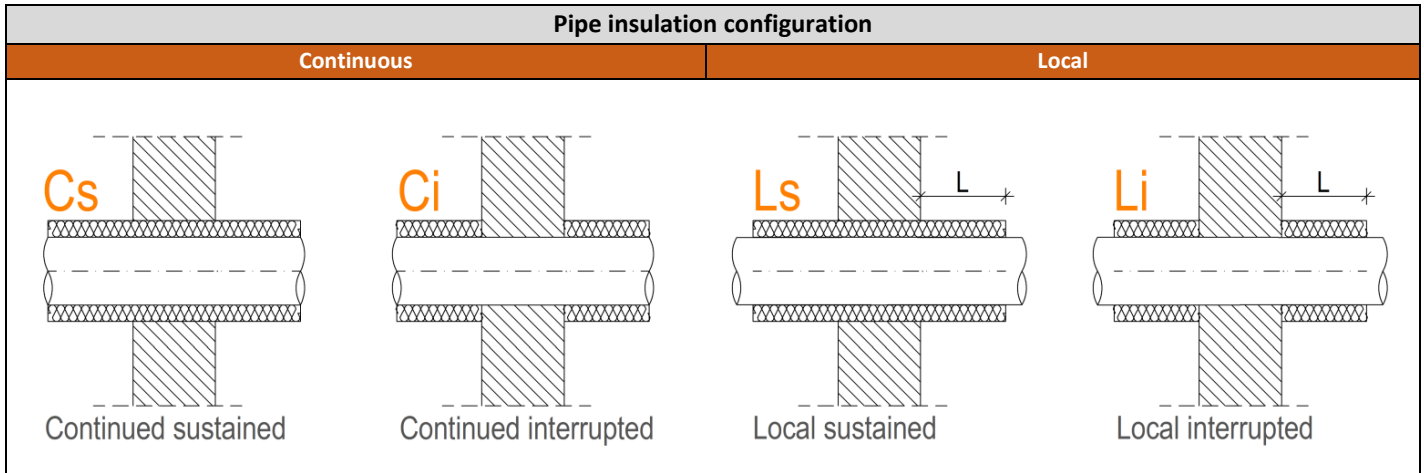

Type of penetrating element				Fire resistance classification		
MINERAL WOOL INSULATED METAL PIPES Density of mineral wool $\rho \geq 90 \text{ kg / m}^3$		Pipe wall thickness (mm)	Insulation* length (mm)	Insulation thickness [mm]	Foam inj. depth $b \geq 144 \text{ mm}$	Foam injection depth $b \geq 200 \text{ mm}$
Metal pipes with mineral wool insulation	$\varnothing \leq 35,0 \text{ mm}$	1,0 – 14,2	(insulation configuration: Ls, Cs, Li, Ci) $L \geq 428$	≥ 30	EI 60 – C/U	wall: EI 90 – C/U; E 120 – C/U floor: EI 120 – C/U
	$\varnothing \leq 54,0 \text{ mm}$			≥ 30		
	$\varnothing \leq 88,9 \text{ mm}$			≥ 528		
Metal pipes with mineral wool insulation	$\varnothing \leq 168,3 \text{ mm}$		(Ls, Cs, Li, Ci) ≥ 596	≥ 50		wall: EI 120 – C/U floor: EI 90 – C/U
AF/Armaflex INSULATED METAL PIPES		Pipe wall thickness (mm)	Insulation length (mm)	Insulation thickness [mm]	Foam inj. depth $b \geq 144 \text{ mm}$	Foam injection depth $b \geq 200 \text{ mm}$
Metal pipes with AF/Armaflex insulation	$\varnothing \leq 35,0 \text{ mm}$	1,0 – 14,2	(insulation config. Ls, Cs): ≥ 500	9,0 – 35,0	EI 60 – C/U	EI 90 – C/U
	$\varnothing \leq 42,0 \text{ mm}$	1,5 – 14,2		9,0 – 36,5		
	$\varnothing \leq 54,0 \text{ mm}$	2,0 – 14,2		9,0 – 38,0		
	$\varnothing \leq 88,9 \text{ mm}$			41,5		
Foamglas® - PSH		Pipe wall thickness (mm)	Insulation length (mm)	Insulation thickness [mm]	Foam inj. depth $b \geq 144 \text{ mm}$	Foam injection depth $b \geq 200 \text{ mm}$
Foamglas® - PSH insulated metal pipes	$\varnothing \leq 28,0 \text{ mm}$	1,0 – 14,2	(insulation config. Ls, Cs) ≥ 500	25,0 – 50,0	-	EI 120 – C/U
	$\varnothing \leq 54,0 \text{ mm}$			25,0 – 50,0		wall: EI 90 – C/U; E 120 – C/U floor: EI 120 – C/U
				50,0		EI 120 – C/U
	$\varnothing \leq 88,9 \text{ mm}$			40,0		wall: EI 120 – C/U floor: EI 90 – C/U; E 120 – C/U

INTU FR FOAM 2K

Fire protection foam

TDS TECHNICAL DATA SHEET

➔ SOLUTION DETAILS

FLEXIBLE WALLS with thickness $c \geq 94$ mm

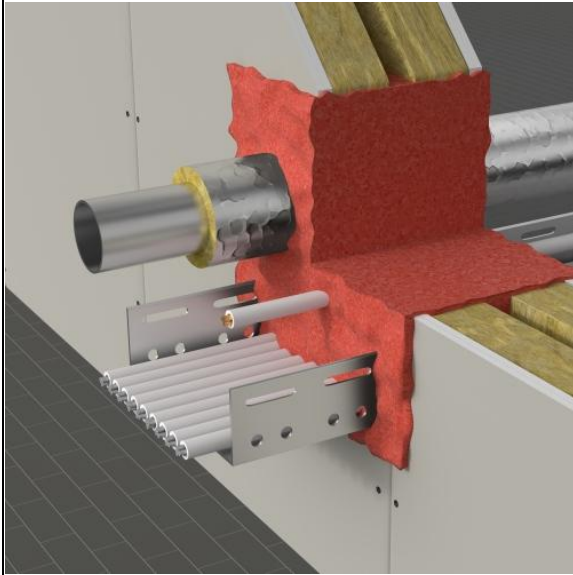

Fig. 1 Mixed penetration seal in flexible wall

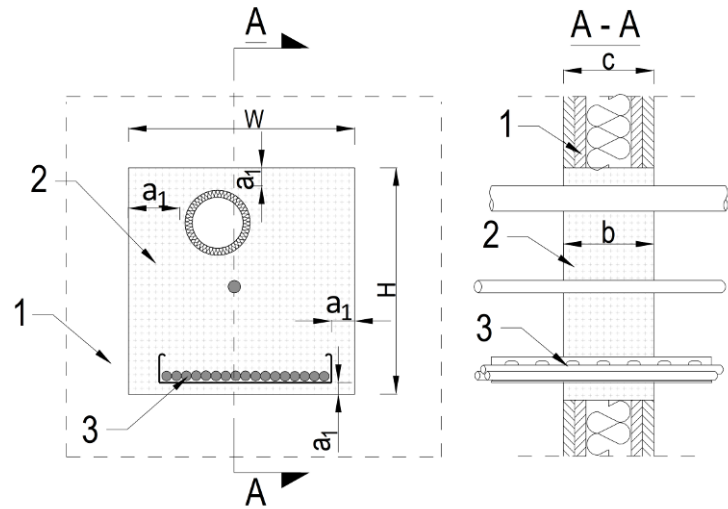
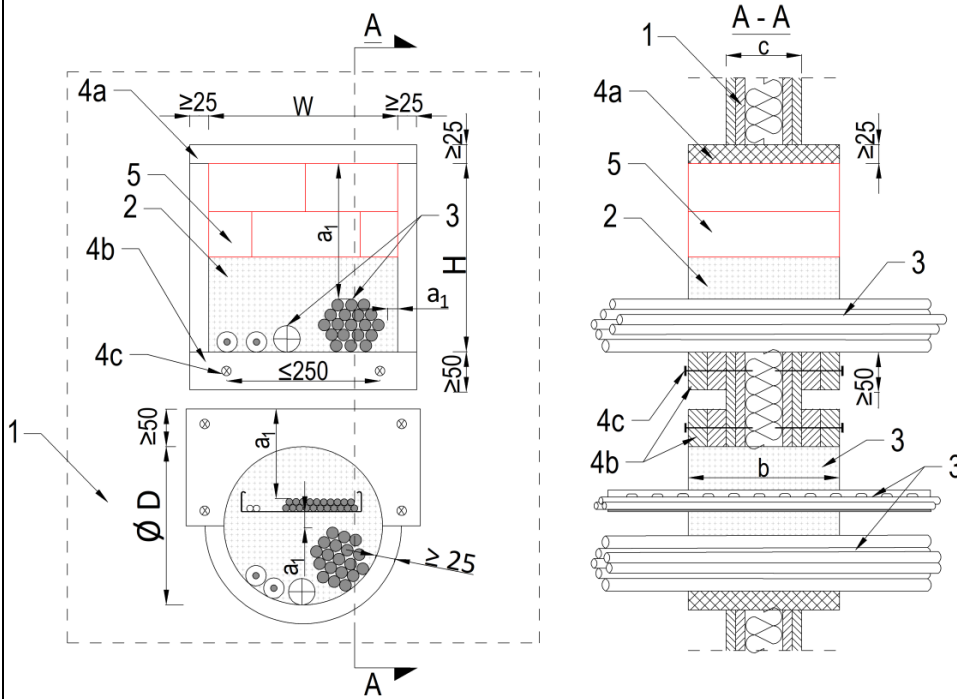

Fig. 2 Cable penetration seal in flexible wall - detail with increased wall thickness



1. Flexible wall with thick. $c \geq 94$ mm
 2. Filling with **INTU FR FOAM 2K**, depth b in accordance with the tables above
 3. Cable / cable bundles / cables in trays / mixed penetration seals
 - 4a. Facing made of two layers of gypsum board (min. thickness 2×12.5 mm) or silicate board (min. thickness 25 mm)
 - 4b. Increasing the wall thickness on one / both sides to at least the min. thickness of the penetration seal (installation of the board around the opening, board width ≥ 50 mm)
 - 4c. Fixing with screws to plaster / silicate boards
 5. **INTU FR BRICK** filling
- * **INTU FR FOAM 2K** and **INTU FR BRICK** products can be used alternatively

Minimum mounting distance:
 $a_1 \geq 0$ mm

INTU FR FOAM 2K

Fire protection foam

TDS TECHNICAL DATA SHEET

RIGID WALLS with thickness $c \geq 100$ mm

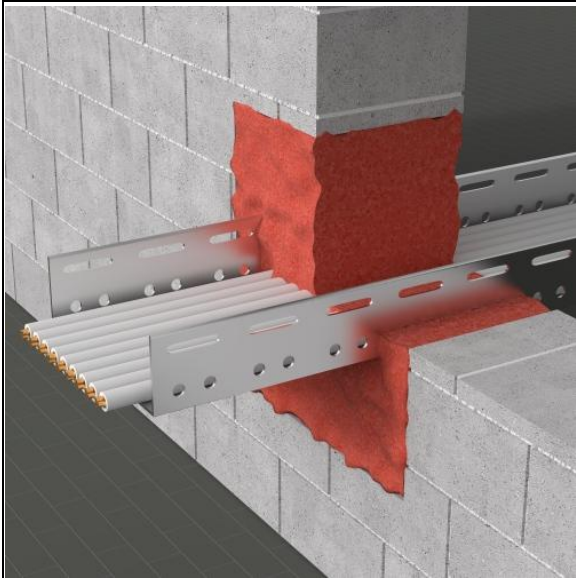

Fig. 3 Cable penetration seal in rigid wall

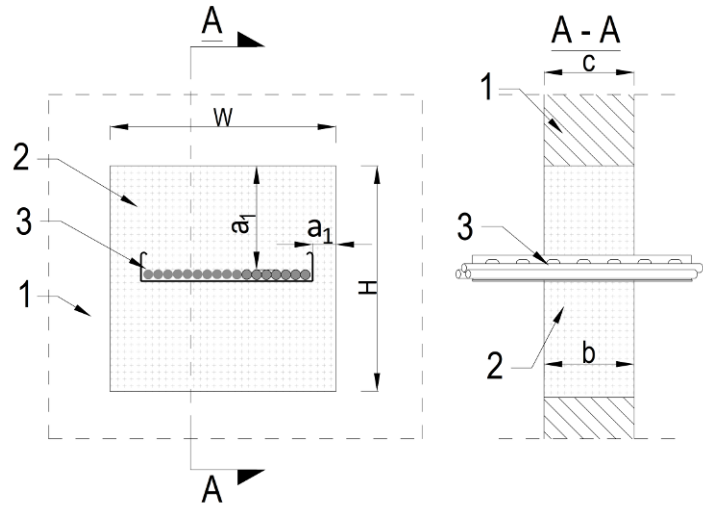
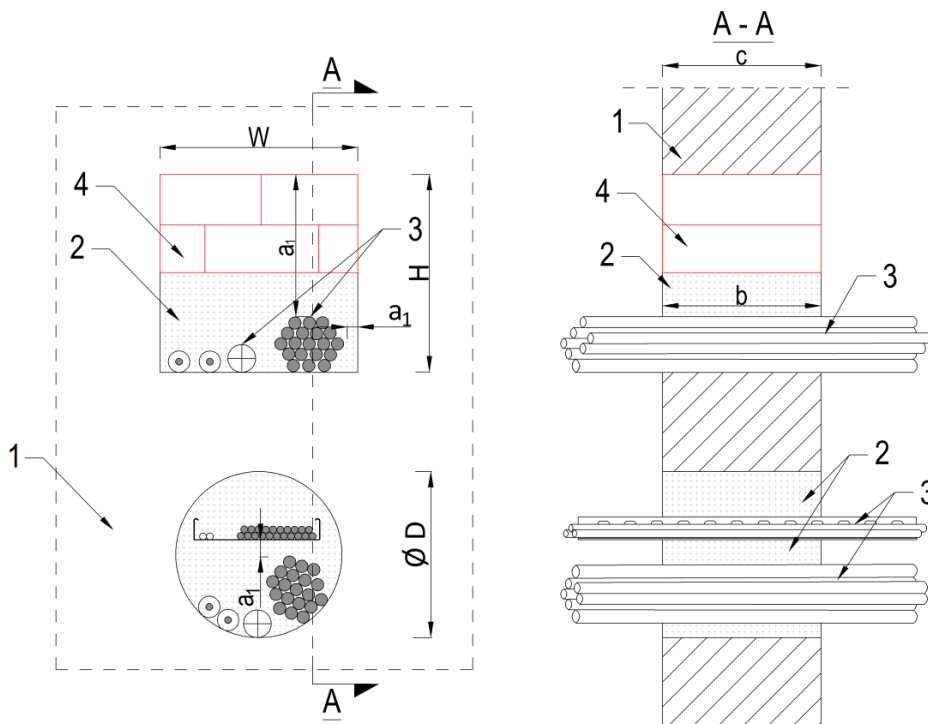

Fig. 4 Cable penetration seal in rigid wall



1. Rigid wall with thick. $c \geq 100$ mm
 2. Filling with **INTU FR FOAM 2K**, depth b in accordance with the tables above
 3. Cable / cable bundles / cables in trays / mixed penetration seals
 4. **INTU FR BRICK** filling
- * **INTU FR FOAM 2K** and **INTU FR BRICK** products can be used alternatively

Minimum mounting distance:
 $a_1 \geq 0$ mm

INTU FR FOAM 2K

Fire protection foam

TDS TECHNICAL DATA SHEET

RIGID FLOOR with thickness $c \geq 150$ mm

Fig.5 Cable penetration seal in the floor - detail with increased floor thickness

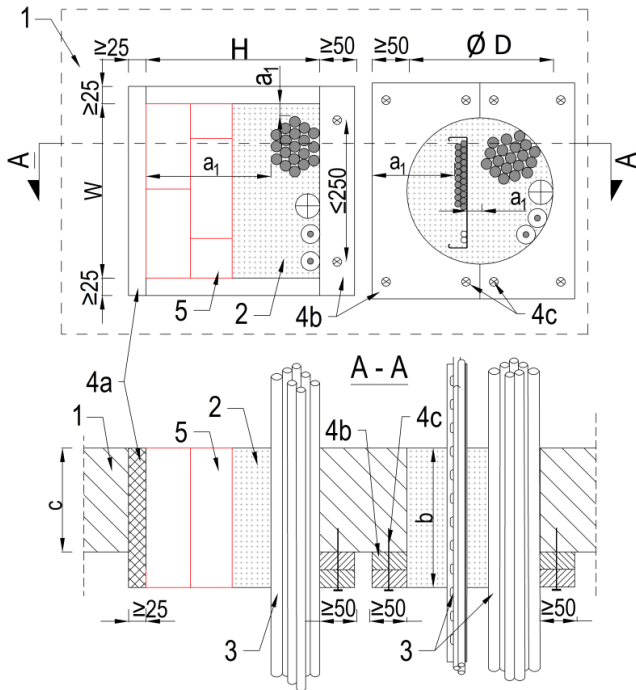

1. Rigid floor with thick. $c \geq 150$ mm
 2. Filling with **INTU FR FOAM 2K**, depth b in accordance with the tables above
 3. Cable / cable bundles / cables in trays / mixed penetration seals
 - 4a. Facing made of two layers of gypsum board (min. thickness 2×12.5 mm) or silicate board (min. thickness 25 mm)
 - 4b. Increasing the wall thickness on one / both sides to at least the min. thickness of the penetration seal (installation of the board around the opening, board width ≥ 50 mm)
 - 4c. Fixing with screws to plaster/ silicate boards
 5. **INTU FR BRICK** filling
- * **INTU FR FOAM 2K** and **INTU FR BRICK** products can be used alternatively

Minimum mounting distance:
 $a_1 \geq 0$ mm

Fig.6 Cable penetration seal in the floor - detail with enough floor thickness

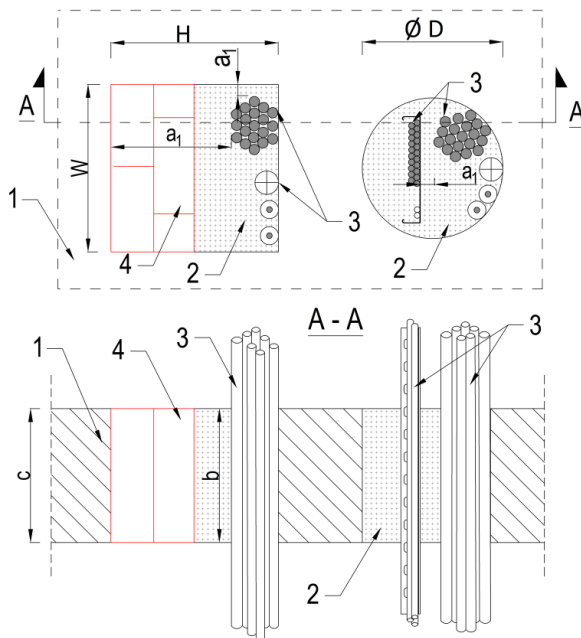

1. Rigid floor with thick. $c \geq 150$ mm
 2. Filling with **INTU FR FOAM 2K**, depth b in accordance with the tables above
 3. Cable / cable bundles / cables in trays / mixed penetration seals
 4. **INTU FR BRICK** filling
- * **INTU FR FOAM 2K** and **INTU FR BRICK** products can be used alternatively

Minimum mounting distance:
 $a_1 \geq 0$ mm

INTU FR FOAM 2K

Fire protection foam

TDS TECHNICAL DATA SHEET

Example of use INTU FR FOAM 2K in mixed penetration seal

Fig. 7 Mixed penetration seal - minimum working clearances

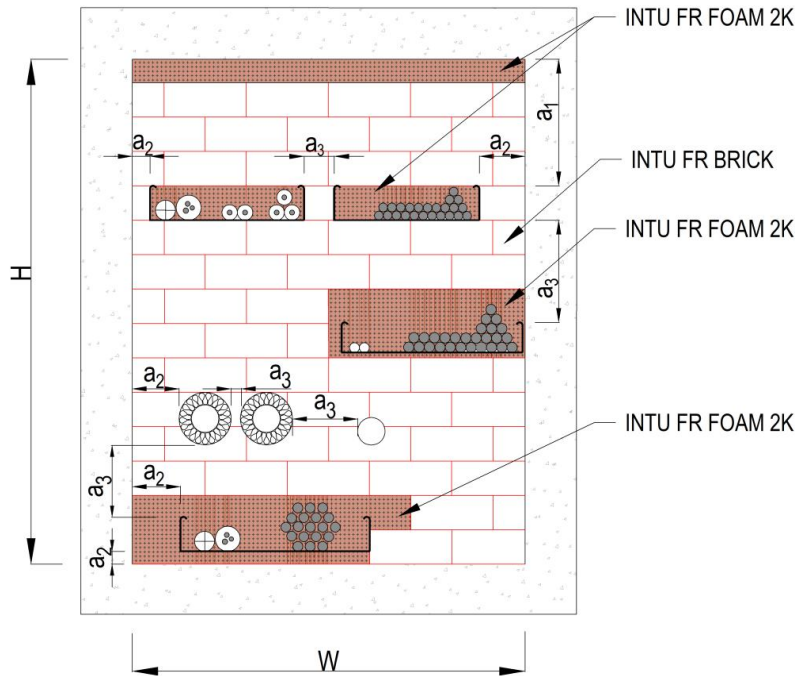

Minimum working clearances in accordance with Table 3

a₁-penetrating element / top edge of penetration seal

a₂-penetrating element /side or lower edge of penetration seal

a₃-penetrating element / penetrating element

Example of use INTU FR FOAM 2K in single pipe with / without insulation penetration seal or single cable

Fig. 8 Pipe with insulation / pipe without insulation penetration seal in wall

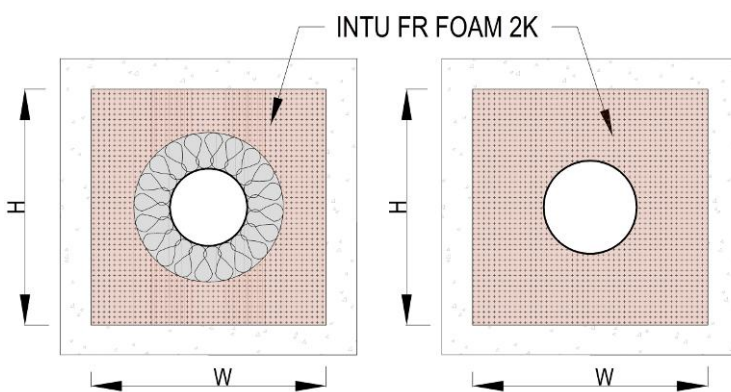

Fig. 9 Single cable penetration seal in floor

